

Operator's Manual

Rad-97™ Pulse CO-Oximeter®



These operating instructions provide the necessary information for proper operation of all models of the Rad-97. There may be information provided in this manual that is not relevant for your system. General knowledge of pulse oximetry and an understanding of the features and functions of Rad-97 are prerequisites for its proper use. Do not operate Rad-97 without completely reading and understanding these instructions.

Note: Cleared Use Only: The device and related accessories are cleared by the Food and Drug Administration (FDA) and are CE Marked for noninvasive patient monitoring and may not be used for any processes, procedures, experiments, or any other use for which the device is not intended or cleared by the applicable regulatory authorities, or in any manner inconsistent with the directions for use or labeling.

Notice: Purchase or possession of this device does not carry any express or implied license to use with replacement parts which would, alone or in combination with this device, fall within the scope of one of the relating patents.

CAUTION: Federal (USA) law restricts this device to sale by or on the order of a physician. See instructions for use for full prescribing information, including indications, contraindications, warnings and precautions.

For professional use. See instructions for use for full prescribing information, including indications, contraindications, warnings, and precautions.

Wireless Radio

Contains: FCC ID: VKF-MWM1 | Model: Rad-97 | IC: 7362A-MWM1 | IC Model: MWM1

Masimo Corporation
40 Parker
Irvine, CA 92618, USA
Tel.: 949-297-7000
Fax.: 949-297-7001
www.masimo.com



EU authorized representative for Masimo Corporation:



MDSS GmbH
Schiffgraben 41
D-30175 Hannover, Germany



MEDICAL ELECTRICAL EQUIPMENT
WITH RESPECT TO ELECTRIC SHOCK, FIRE AND MECHANICAL HAZARDS ONLY
IN ACCORDANCE WITH
ANSI/AAMI ES 60601-1:2005, CAN/CSA C22.2 No. 60601-1:2008, and
applicable Particular (EN/ISO 80601-2-61:2011) and related Collateral (IEC
60601-1-8:2006) Standards for which the product has been found to comply by
Intertek.

Patents: www.masimo.com/patents.htm

©, Adaptive Probe Off Detection®, APOD®, Discrete Saturation Transform®, DST®, FastSat®, FST®, Masimo®, Pulse CO-Oximeter®, PVi®, rainbow®, rainbow Responsible®, RRa®, SET®, Signal Extraction Technology®, Signal IQ®, SpCO®, SpHb®, and SpMet® are federally registered trademarks of Masimo Corporation.

Rad-97™, rainbow Acoustic Monitoring™, rainbow SET™, RAM™, Adaptive Threshold Alarm™, In Vivo Adjustment™, ORI™, X-Cal™, Kite™, SpOC™, and RRp™ are trademarks of Masimo Corporation. All other trademarks and registered trademarks are property of their respective

owners. The use of the trademark Patient SafetyNet is under license from University HealthSystem Consortium.

All other registered trademarks and trademarks are property of their respective owners.

© 2017 Masimo Corporation

Contents

About This Manual	7
Product Description, Features and Indications for Use	9
Product Description	9
Indications for Use	10
Contraindications	11
Safety Information, Warnings and Cautions	13
Safety Warnings and Cautions	13
Performance Warnings and Cautions	15
Cleaning and Service Warnings and Cautions	20
Compliance Warnings and Cautions	21
Chapter 1: Technology Overview	23
Signal Extraction Technology® (SET®)	23
rainbow Pulse CO-Oximetry Technology	26
rainbow Acoustic Monitoring™ (RAM™)	31
Chapter 2: Description	35
General System Description	35
Features	36
Chapter 3: Setting Up	39
Unpacking and Inspection	39
Preparation for Use	39
Guidelines for Setting Up	39
Powering the Rad-97 ON and OFF	40
Initial Battery Charging	41
Nurse Call Connection	41
Attach NIBP Cuff	42
Masimo Kite	42
Third-Party Devices	42
Chapter 4: Operation	43
Using the Touchscreen and Home Button	43
About the Main Screen	48
About the System Status Light	56

Accessing Main Menu Options -----	57
Parameter Settings -----	60
Noninvasive Blood Pressure (NIBP) Settings -----	80
Sounds -----	85
Device Settings -----	86
About -----	97
Trends -----	97
Rad-97 Screenshot Capture -----	99
Patient Admit/Discharge -----	101
Chapter 5: Profiles -----	103
Profiles Overview -----	103
Changing Profiles -----	103
Profiles Settings -----	106
Replacing Factory Default Settings for Adult, Pediatric and Neonatal Profiles -----	107
Chapter 6: Noninvasive Blood Pressure (NIBP) -----	109
Operation - NIBP -----	109
Patient Category -----	109
Patient Conditions -----	109
Cuff Selection and Placement -----	110
Blood Pressure Measurement -----	112
Chapter 7: Admit to and Discharge from Patient SafetyNet -----	117
Not Admitted -----	117
Admitting a Patient -----	118
Discharging a Patient -----	120
Chapter 8: Third-Party Devices -----	121
Connect Device to Rad-97 -----	121
Chapter 9: Alarms and Messages -----	123
Alarm Interface -----	123
About Alarms -----	124
Adaptive Threshold Alarm (ATA) Feature -----	127
3D Alarms -----	128
Messages -----	130
Noninvasive Blood Pressure (NIBP) Messages -----	135

Chapter 10: Troubleshooting	137
Troubleshooting Measurements	137
Troubleshooting Rad-97	140
Chapter 11: Specifications	145
Pulse CO-Oximetry Specifications	145
Noninvasive Blood Pressure (NIBP) Specifications	150
Electrical	151
Environmental	152
Physical Characteristics	152
Alarms	153
Display Indicators	153
Compliance	154
Connectors	155
Wireless Specifications	155
Guidance and Manufacturer's Declaration-Electromagnetic Emissions	158
Guidance and Manufacturer's Declaration-Electromagnetic Immunity	158
Recommended Separation Distances	161
Symbols	162
Citations	164
Chapter 12: Service and Maintenance	167
Cleaning	167
Nurse Call Setting Connections	167
Performance Verification	168
Calibration	170
Maintenance	172
Repair Policy	173
Return Procedure	173
Contacting Masimo	173
Appendix: Concepts of Alarm Response Delay	177
Concepts of Alarm Response Delay	177
Index	179

About This Manual

This manual explains how to set up and use Rad-97™ Pulse CO-Oximeter®. Important safety information relating to general use of Rad-97 appears in this manual. Read and follow any warnings, cautions, and notes presented throughout this manual. The following are explanations of warnings, cautions, and notes.

A *warning* is given when actions may result in a serious outcome (for example, injury, serious adverse effect, death) to the patient or user.

WARNING: This is an example of a warning statement.

A *caution* is given when any special care is to be exercised by the patient or user to avoid injury to the patient, damage to this device, or damage to other property.

CAUTION: This is an example of a caution statement.

A *note* is given when additional general information is applicable.

Note: This is an example of a note.

Product Description, Features and Indications for Use

Product Description

Rad-97™ Pulse CO-Oximeter® is a non-invasive device intended to monitor functional oxygen saturation of arterial hemoglobin (SpO₂), pulse rate (PR), perfusion index (Pi), and Pleth Variability Index (PVi) along with optional non-invasive measurements of total hemoglobin (SpHb), carboxyhemoglobin (SpCO), total oxygen content (SpOC), methemoglobin (SpMet), Acoustic Respiration Rate (RRa), Oxygen Reserve Index (ORI)*, and Pleth Respiration Rate (RRp)*.

The following key features are available for Rad-97:

- Masimo SET and rainbow SET technology performance.
- SpO₂ and pulse rate monitoring in motion and low perfusion environments.
- Continuous and non-invasive monitoring of carboxyhemoglobin (SpCO), methemoglobin (SpMet), and total hemoglobin (SpHb).
- Respiration Rate (RR) is measured using:
 - Acoustic (RRa)
 - Plethysmographic waveform (RRp)*
- Oxygen Reserve Index (ORI)*, an index to measure changes in oxygen states under hyperoxic conditions.
- Wireless radio for transfer of parameter data.
- Sleep Study and optional Home operational modes.
- Optional integrated Noninvasive Blood Pressure (NIBP) technology.
- Designed for third party measurement expansion to allow for additional platform measurements.
- Ability to display data on a secondary display.

For all prescribing information and instructions for use of the compatible medical devices connected to Rad-97, see the Operator's Manual or Instructions for Use for the specific medical device.

*** Currently not available in the U.S.A. and territories relying on FDA market clearance.**

Regulatory Notice

The following features are NOT AVAILABLE.

Feature	NOT AVAILABLE in U.S.A. and territories relying on FDA market clearance
SpO ₂	

Feature	NOT AVAILABLE in U.S.A. and territories relying on FDA market clearance
PR	
Pi	
PVi	
SpHb	
SpCO	
SpOC	
SpMet	
RRa	
RRp	X
ORi	X
ATA	X
In-Vivo	X
NIBP	

Indications for Use

The Masimo Rad-97 and Accessories are indicated for hospitals, hospital-type facilities, mobile, and home environments.

The Masimo Rad-97 and Accessories can communicate with network systems for supplemental remote viewing and alarming (e.g., at a central station).

The Masimo Rad-97 and Accessories are indicated for the continuous non-invasive monitoring of functional oxygen saturation of arterial hemoglobin (SpO₂), pulse rate (PR), carboxyhemoglobin saturation (SpCO), methemoglobin saturation (SpMet), total hemoglobin concentration (SpHb), and/or respiratory rate (RRa). The Masimo Rad-97 and Accessories are indicated for use with adult, pediatric, and neonatal patients during both no motion and motion conditions, and for patients who are well or poorly perfused. In addition, the Masimo Rad-97 and Accessories are indicated to provide the continuous non-invasive monitoring data obtained from the Masimo Rad-97 and Accessories for functional oxygen saturation of arterial hemoglobin (SpO₂) and pulse rate (PR) to multi-parameter devices for the display on those devices.

The Masimo Rad-97 and Accessories are not intended to be used as the sole basis for making diagnosis or treatment decisions related to suspected carbon monoxide poisoning; it is

intended to be used in conjunction with additional methods of assessing clinical signs and symptoms.

The optional Nomoline Capnography product family is intended to be connected to other medical backboard devices for monitoring of breath rate and CO₂. The Nomoline Capnography product family is intended to be connected to a patient breathing circuit for monitoring of inspired/expired gases during anesthesia, recovery and respiratory care. The environment is the operating suite, intensive care unit and patient room. The intended patient population is adult, pediatric and infant patients.

The optional non-invasive blood pressure (NIBP) module is indicated for the noninvasive measurement of arterial blood pressure. The NIBP module is designed to measure blood pressure for patient population described in the following table:

Patient Population	Approximate Age Range
Newborn (neonate)	Birth to 1 month of age
Infant	1 month to 2 years of age
Child	2 to 12 years of age
Adolescent	12-21 years of age
Adult	21 years of age and older

Contraindications

The Rad-97 is not intended for use as an apnea monitor.

Safety Information, Warnings and Cautions

CAUTION: Rad-97 is to be operated by, or under the supervision of, qualified personnel only. Read the manual, accessories directions for use, all precautionary information, and specifications before use. Refer to Operator's Manuals of Patient SafetyNet and Kite for additional safety information, warnings, and cautions.

Safety Warnings and Cautions

WARNING: Do not use Rad-97 if it appears or is suspected to be damaged. Damage to the device can result in exposed electrical circuits that may cause patient harm.

WARNING: Do not adjust, repair, open, disassemble, or modify the Rad-97. Damage to the device may result in degraded performance and/or patient injury.

WARNING: Do not start or operate the Rad-97 unless the setup was verified to be correct. Improper set-up of this device may result in degraded performance and/or patient injury.

WARNING: Do not place the Rad-97 or accessories in any position that might cause it to fall on the patient.

WARNING: Only use Masimo authorized devices with Rad-97. Using unauthorized devices with Rad-97 may result in damage to the device and/or patient injury.

WARNING: All sensors and cables are designed for use with specific devices. Verify the compatibility of the device, cable, and sensor before use; otherwise degraded performance and/or patient injury can result.

WARNING: Do not use the Rad-97 in the presence of flammable anesthetics or other flammable substance in combination with air, oxygen-enriched environments, or nitrous oxide to avoid risk of explosion.

WARNING: Do not use the Rad-97 during magnetic resonance imaging (MRI) or in an MRI environment.

WARNING: Rad-97 may be used during defibrillation. However, to reduce the risk of electric shock, the operator should not touch the Rad-97 during defibrillation.

WARNING: Electrical Shock Hazard: To protect against injury, follow the directions below:

- Avoid placing the device on surfaces with visible liquid spills.
- Do not soak or immerse the device in liquids.
- Do not attempt to sterilize the device.
- Use cleaning solutions only as instructed in this Operator's Manual.
- Do not attempt to clean the Rad-97 while monitoring patient.

WARNING: To ensure safety, avoid placing anything on the device during operation.

WARNING: As with all medical equipment, carefully route patient cables to reduce the possibility of patient entanglement or strangulation.

CAUTION: Do not place the Rad-97 where the controls can be changed by the patient.

CAUTION: Do not place Rad-97 where the appliance inlet or the AC power plug cannot be readily disconnected.

CAUTION: Use a grounded outlet for proper equipment grounding. A hospital-grade outlet is required.

CAUTION: To avoid risk of electrical shock, this equipment must only be connected to a supply mains with a protective earth connection. Do not under any circumstances remove the grounding conductor from the power plug.

CAUTION: Only use the AC power cable provided by Masimo. Using a different AC power cable could cause damage to Rad-97. Check the power cord and plug to ensure that it is intact and undamaged.

CAUTION: To ensure patient electrical isolation, all external device connections to the Data Output/Nurse Call connectors must be IEC 60950-1, IEC 60601-1, or UL1069 compliant.

Note: If there is any doubt about the integrity of the protective earth conductor arrangement, operate the Rad-97 on internal battery power until the AC power supply protective conductor is fully functional.

Note: Disconnect the device from AC mains by removing the AC power cord connector from the appliance inlet.

Note: Do not monitor more than a single patient at a time on Rad-97.

Note: Use and store the Rad-97 in accordance with specifications. See the Specifications section in this manual.

Noninvasive Blood Pressure

WARNING: Only use Rad-97 in Neonatal mode with a neonatal blood pressure cuff to measure blood pressure on neonates.

WARNING: Neonatal blood pressure measurements must always use a 3 meter hose in order to avoid overpressure error caused by lack of air volume within the overall pneumatic system.

WARNING: Frequently check the blood pressure monitoring site to ensure adequate circulation.

WARNING: Do not apply the cuff to a limb that is on the same side of a mastectomy.

WARNING: Do not use or stop blood pressure measurements if the patient appears to be affected by the pressurization of the cuff due to a physical condition (i.e. pregnant, pre-eclamptic, etc.)

WARNING: Too frequent blood pressure measurements can cause injury to the patient due to blood flow interference.

WARNING: Do not attach the cuff to a limb being used for IV infusions or any other intravascular access, therapy or an arterio-venous (A-V) shunt. The cuff inflation can temporarily block blood flow, potentially causing harm to the patient.

CAUTION: Applying the blood pressure cuff over a wound can cause further injury.

CAUTION: A compressed or kinked connection hose may cause continuous cuff pressure resulting in blood flow interference and potentially harmful injury to the patient.

Kite

WARNING: Do not adjust, repair, open, disassemble, or physically modify the Kite host device. Injury to personnel or equipment damage could occur. Return the Kite host device for servicing.

Performance Warnings and Cautions

WARNING: Rad-97 should not be used as the sole basis for medical decisions. It must be used in conjunction with clinical signs and symptoms.

WARNING: The Rad-97 and Accessories are not intended to be used as the sole basis for making diagnosis or treatment decisions related to suspected carbon monoxide poisoning; it is intended to be used in conjunction with additional methods of assessing clinical signs and symptoms.

WARNING: If any measurement seems questionable, first check the patient's vital signs by alternate means and then check Rad-97 for proper functioning.

WARNING: Variation in hemoglobin measurements may be profound and may be affected by sample type, body positioning, as well as other physiological conditions. As with most hemoglobin data, Rad-97 trend data should be scrutinized in light of a specific patient condition. Any results exhibiting inconsistency with the patient's clinical status should be repeated and/or supplemented with additional data.

WARNING: Rad-97 is not an apnea monitor.

WARNING: Rad-97 should not be used as a replacement or substitute for ECG-based arrhythmia analysis.

WARNING: Rad-97 may be used during defibrillation. This may affect the accuracy or availability of the parameters and measurements.

WARNING: Rad-97 may be used during electrocautery. This may affect the accuracy or availability of the parameters and measurements.

WARNING: Avoid placing Rad-97 against a surface that may cause the alarm to be muffled. This may result in the inability to detect the audible alarms.

WARNING: Rad-97 may not fully charge in a high ambient temperature environment.

WARNING: Properly apply sensors according to sensor's directions for use. Misapplied sensor or sensors that become partially dislodged may cause no or incorrect readings.

WARNING: Select a well perfused site for monitoring, very low perfusion at the monitored site may result in no or incorrect readings.

WARNING: Do not use Rad-97 on patients that have been injected with dyes or any substance containing dyes, the change usual blood pigmentation may cause no or incorrect readings.

WARNING: Display parameter may not be accurate when a low SIQ message is provided. Clinicians should consider additional information to supplement values to completely understand the patient's condition.

WARNING: If SpO₂ values indicate hypoxemia, a laboratory blood sample should be taken to confirm the patient's condition.

WARNING: SpO₂ is empirically calibrated in healthy adult volunteers with normal levels of carboxyhemoglobin (COHb) and methemoglobin (MetHb).

WARNING: Optical, pleth-based measurements (e.g. SpO₂, SpHb, SpOC, SpMet, SpCO, RRp, and ORi) can be affected by the following:

- Improper sensor application or use of use of incorrect sensor.
- Blood pressure cuff applied to the same arm as the sensor site.
- Intravascular dyes such as indocyanine green or methylene blue.
- Venous congestion.
- Abnormal venous pulsations (e.g. tricuspid valve regurgitation, Trendelenburg position).
- Abnormal pulse rhythms due to physiological conditions or induced through external factors (e.g. cardiac arrhythmias, intra-aortic balloon, etc.).
- Externally applied coloring and texture such as nail polish, acrylic nails, glitter, etc.
- Moisture, birthmarks, skin discoloration, nail aberration, deformed fingers, or foreign objects in the light path.
- Elevated levels of bilirubin.
- Physiological conditions that can significantly shift the oxygen disassociation curve.
- A physiological condition that may effect vasomotor tone or changes in vasomotor tone.

WARNING: Inaccurate SpO₂ readings may be caused by:

- Elevated levels of COHb and/or MetHb.
- Severe anemia.
- Extremely low arterial perfusion.
- Excessive induced motion.
- Hemoglobinopathies (qualitative defects including sickle cell) and Hemoglobin synthesis disorders (Quantitative defects such as Thalassemias).

WARNING: Inaccurate SpHb and SpOC readings may be caused by:

- Low arterial perfusion.
- Motion induced artifact.
- Low arterial oxygen saturation levels.
- Elevated COHb and/or MetHb levels.
- Hemoglobinopathies (qualitative defects including sickle cell) and Hemoglobin synthesis disorders (quantitative defects such as Thalassemias).
- Severe anemia.

WARNING: Inaccurate SpCO readings may be caused by:

- Elevated methemoglobin levels in the range of >15%.

- Hemoglobinopathies (qualitative defects including sickle cell) and Hemoglobin synthesis disorders (quantitative defects such as Thalassemias).
- Extremely elevated hemoglobin levels.
- Low arterial perfusion.
- Low arterial oxygen saturation levels including altitude induced hypoxemia.
- Motion induced artifact.
- Severe anemia.

WARNING: SpCO readings may not be provided if there are Low arterial oxygen saturation levels or elevated methemoglobin levels.

WARNING: Inaccurate SpMet readings may be caused by:

- Elevated carboxyhemoglobin levels in the range of > 3%.
- Hemoglobinopathies (qualitative defects including sickle cell) and Hemoglobin synthesis disorders (quantitative defects such as Thalassemias).
- Extremely elevated hemoglobin levels.
- Low arterial perfusion.
- Low arterial oxygen saturation levels including altitude induced hypoxemia.
- Motion induced artifact.
- Physiological conditions that can significantly shift the oxygen disassociation curve.
- Severe anemia.

WARNING: Inaccurate RRa measurements may be caused by:

- Improper sensor application or use of use of incorrect sensor.
- Abnormal pulse rhythms due to physiological conditions or induced through external factors (e.g. Cardiac arrhythmias, intra-aortic balloon, etc.).
- Motion artifact.
- Excessive ambient or environmental noise.

WARNING: Inaccurate RRp readings may be caused by:

- Low arterial perfusion.
- Motion induced artifact.
- Severe anemia.

WARNING: Inaccurate ORi readings may be caused by:

- Low arterial perfusion.
- Motion induced artifact.
- Elevated COHb and/or Methb levels.
- Hemoglobinopathies (qualitative defects including sickle cell) and Hemoglobin synthesis disorders (Quantitative defects such as Thalassemias).

- Hypotension, severe vasoconstriction, severe anemia, or hypothermia.

WARNING: ORi is not intended as a replacement for SpO₂ monitoring, PaO₂ monitoring, or as a sole indicator of the patient condition.

WARNING: Wireless communication of alarms to a secondary monitoring station should not be relied upon as a primary alarm.

CAUTION: ORi may not indicate additional changes in oxygen states above 200 mmHg of PaO₂.

CAUTION: If using Rad-97 during full body irradiation, keep the sensor out of the radiation field. If the sensor is exposed to the radiation, the reading might be inaccurate or the device might read zero for the duration of the active irradiation period.

CAUTION: When patients are undergoing photodynamic therapy they may be sensitive to light sources. Pulse oximetry may be used only under careful clinical supervision for short time periods to minimize interference with photodynamic therapy.

CAUTION: High ambient light sources such as surgical lights (especially those with a xenon light source), bilirubin lamps, fluorescent lights, infrared heating lamps, and direct sunlight can interfere with the performance of the sensor.

CAUTION: To prevent interference from ambient light, ensure that the sensor is properly applied, and cover the sensor site with opaque material, if required. Failure to take this precaution in high ambient light conditions may result in inaccurate measurements.

CAUTION: If the Low Perfusion message is frequently displayed, find a better perfused monitoring site. In the interim, assess the patient and, if indicated, verify oxygenation status through other means.

CAUTION: To minimize radio interference, other electrical equipment that emits radio frequency transmissions should not be in close proximity to Rad-97.

CAUTION: Do not place the Rad-97 near electrical equipment that may affect the device, preventing it from working properly.

CAUTION: Failure to charge Rad-97 promptly after a Low Battery alarm may result in the device shutting down.

CAUTION: Do not connect to an electrical outlet controlled by a wall switch or dimmer.

CAUTION: In order to establish and maintain Rad-97's minimum Quality of Service, the following network specifications should be met before and after installation:

- **Wired Network Connection**
During Ping Test, passing result if:
 - a. At least 98% of packets have latency \leq 30 milliseconds, and
 - b. No more than 2 % packets loss.
- **Wireless Network Connection**
During Ping Test, passing result if:
 - a. At least 98% of packets have latency \leq 100 milliseconds,
 - b. No more than 2 % packets loss, and
 - c. Primary access point signal strength at least -67 dBm.

CAUTION: The wireless quality of services may be influenced by the presence of other devices that may create radio frequency interference (RFI). Some RFI devices to consider are as follows: electrocautery equipment, cellular telephones, wireless PC and tablets, pagers, RFID,

MRI electrically powered wheelchair, etc. When used in the presence of potential RFI devices, consideration should be taken to maximize separation distances and to observe for any potential signs of interference such as loss of communication or reduced Wi-Fi signal strength.

CAUTION: To ensure that alarm limits are appropriate for the patient being monitored, check the limits each time Rad-97 is used.

CAUTION: Replace the cable or sensor when a replace sensor or when a low SIQ message is consistently displayed while monitoring consecutive patients after completing the low SIQ troubleshooting steps listed in the troubleshooting section.

Note: Cables and sensors are provided with X-Cal™ technology to minimize the risk of inaccurate readings and unanticipated loss of patient monitoring. Refer to the Cable or Sensor DFU for the specified duration of patient monitoring time.

Note: SpHb readings may be inaccurate for patients with conditions that may cause edema at the measurement site (eg. kidney disease, pregnancy, etc.).

Note: Physiological conditions that result in loss of pulsatile signal may result in no SpO₂, SpHb, SpOC, SpCO, SpMet, RRp, and ORi readings.

Note: Rad-97 is provided with a Wi-Fi signal indicator as an indication of Wi-Fi communication.

Note: Rad-97's alarm capabilities have been designed to be independent of the Wi-Fi communication feature in order to preserve Rad-97's primary alarms.

Note: Always charge Rad-97 when it is not in use to ensure that the Rad-97 Battery Module remains fully charged.

Note: All batteries lose capacity with age, thus the amount of run time at Low Battery will vary depending upon the age of the Battery Module.

Note: A functional tester cannot be used to assess the accuracy of Rad-97.

Note: When monitoring acoustic respiration, Masimo recommends minimally monitoring both oxygenation (SpO₂) and respiration (RRa).

Note: When using the Maximum Sensitivity setting, performance of the "Sensor Off" detection may be compromised. If the Rad-97 is in this setting and the sensor becomes dislodged from the patient, the potential for false readings may occur due to environmental "noise" such as light, vibration, and excessive air movement.

Noninvasive Blood Pressure

WARNING: Before applying the cuff on the patient, confirm the cuff size is appropriate.

WARNING: When a blood pressure measurement error code occurs, any blood pressure values reported should be disregarded.

CAUTION: If the blood pressure cuff is on the same limb as monitoring equipment (i.e., pulse oximeter probe), the pressurization within the cuff can cause temporary loss of function of the monitoring equipment.

CAUTION: Blood pressure measurements can be affected by the patient's position, physiological condition, and environmental factors.

Note: Physiological conditions that can affect blood pressure measurements include, but are not limited to, cardiac arrhythmias, arterial sclerosis, poor perfusion, diabetes, age, pregnancy, pre-eclampsia, renal diseases, trembling, and shivering.

Kite

WARNING: Kite does not generate or manage alarms. The connected device's alarms, used in conjunction with clinical signs and symptoms, are the primary sources for determining that an alarm condition exists.

CAUTION: Kite is not a primary display. All medical decisions should be made using data on the connected Masimo medical device primary display.

CAUTION: Kite is intended to operate across the facility's network. Unanticipated failure or alteration of network components (including but not limited to: disconnection or malfunctioning of a networking device/switch/router/ethernet cable) may result in loss of connectivity of Kite to other hospital systems. Altering or making changes to the hospital network should be done with proper knowledge.

Patient SafetyNet

Note: The wireless communication status between Rad-97 and Patient SafetyNet is displayed by Patient SafetyNet.

Cleaning and Service Warnings and Cautions

WARNING: Do not attempt to remanufacture, recondition or recycle the Rad-97 as these processes may damage the electrical components, potentially leading to patient harm.

WARNING: To avoid electric shock, always turn off the Rad-97 and physically disconnect the AC power and all patient connections before cleaning.

WARNING: To avoid electric shock, do not attempt to replace or remove the Battery from the Rad-97. Service of Rad-97 should be done by qualified personnel only.

WARNING: Do not incinerate the Rad-97 Battery. The battery should be properly disposed according to local laws and regulations.

CAUTION: Only perform maintenance procedures specifically described in the manual. Otherwise, return the Rad-97 for servicing.

CAUTION: Do not touch, press, or rub the display panels with abrasive cleaning compounds, instruments, brushes, rough-surface materials, or bring them into contact with anything that could scratch the display.

CAUTION: To avoid permanent damage to the Rad-97, do not use undiluted bleach (5% - 5.25% sodium hypochlorite) or any other cleaning solution not recommended.

CAUTION: Do not use petroleum-based or acetone solutions, or other harsh solvents, to clean the Rad-97. These substances affect the device's materials and device failure can result.

CAUTION: Do not submerge the Rad-97 in any cleaning solution or attempt to sterilize by autoclave, irradiation, steam, gas, ethylene oxide or any other method. This will seriously damage the device.

CAUTION: To prevent damage, do not soak or immerse Rad-97 in any liquid solution.

CAUTION: Electrical Shock Hazard: Carry out periodic tests to verify that leakage currents of patient-applied circuits and the system are within acceptable limits as specified by the applicable safety standards. The summation of leakage currents must be checked and in compliance with IEC 60601-1 and UL60601-1. The system leakage current must be checked when connecting external equipment to the system. When an event such as a component drop of approximately 1 meter or greater or a spillage of blood or other liquids occurs, retest before further use. Injury to personnel could occur.

Compliance Warnings and Cautions

WARNING: Any changes or modifications not expressly approved by Masimo shall void the warranty for this equipment and could void the user's authority to operate the equipment.

WARNING: In accordance with international telecommunication requirements, the frequency band of 2.4 GHz and 5.15 to 5.25 GHz is only for indoor usage to reduce potential for harmful interference to co-channel mobile satellite systems.

CAUTION: Disposal of Product: Comply with local laws in the disposal of the device and/or its accessories.

CAUTION: Device contains an internal battery. Dispose of the battery according to required country or regional requirements.

Note: Use Rad-97 in accordance with the Environmental Specifications section in the Operator's Manual.

Note: This device complies with part 15 of the FCC Rules. Operation is subject to the following two conditions: (1) This device may not cause harmful interference, and (2) this device must accept any interference received, including interference that may cause undesired operation.

Note: This equipment has been tested and found to comply with the limits for a Class B digital device, pursuant to part 15 of the FCC Rules. These limits are designed to provide reasonable protection against harmful interference in a residential installation. This equipment generates, uses and can radiate radio frequency energy and, if not installed and used in accordance with the instructions, may cause harmful interference to radio communications. However, there is no guarantee that interference will not occur in a particular installation. If this equipment does cause harmful interference to radio or television reception, which can be determined by turning the equipment off and on, the user is encouraged to try to correct the interference by one or more of the following measures:

- Reorient or relocate the receiving antenna.
- Increase the separation between the equipment and receiver.
- Connect the equipment into an outlet on a circuit different from that to which the receiver is connected.
- Consult the dealer or an experienced radio/TV technician for help.

Note: This equipment has been tested and found to comply with the Class B limits for medical devices according to the EN 60601-1-2: 2007, Medical Device Directive 93/42/EEC. These limits are designed to provide reasonable protection against harmful interference in all establishments, including domestic establishments.

Note: In order to maintain compliance with FCC regulations, shielded cables must be used with this equipment. Operation with non-approved equipment or unshielded cables is likely to result in interference to radio and TV reception. The user is cautioned that changes and

modifications made to the equipment without the approval of manufacturer could void the user's authority to operate this equipment.

Note: To satisfy RF exposure requirements, this device and its antenna must operate with a separation distance of at least 20 cm from all persons and must not be co-located or operating in conjunction with any other antenna or transmitter.

Note: This Class B digital apparatus complies with Canadian ICES-003.

Note: This device complies with Industry Canada license-exempt RSS standard(s). Operation is subject to the following two conditions: (1) this device may not cause interference, and (2) this device must accept any interference, including interference that may cause undesired operation of the device.

Chapter 1: Technology Overview

The following chapter contains general descriptions about parameters, measurements, and the technology used by Masimo products.

Signal Extraction Technology® (SET®)

Masimo Signal Extraction Technology's signal processing differs from that of conventional pulse oximeters. Conventional pulse oximeters assume that arterial blood is the only blood moving (pulsating) in the measurement site. During patient motion, however, the venous blood also moves, causing conventional pulse oximeters to read low values, because they cannot distinguish between the arterial and venous blood movement (sometimes referred to as noise).

Masimo SET® pulse oximetry utilizes parallel engines and adaptive filtering. Adaptive filters are powerful because they are able to adapt to the varying physiologic signals and/or noise and separate them by looking at the whole signal and breaking it down to its fundamental components. The Masimo SET® signal processing algorithm, Discrete Saturation Transform® (DST®), in parallel with Fast Saturation Transform (FST®), reliably identifies the noise, isolates it and, using adaptive filters, cancels it. It then reports the true arterial oxygen saturation for display on the monitor.

Masimo rainbow SET® Parallel Engines

This figure is for conceptual purposes only.

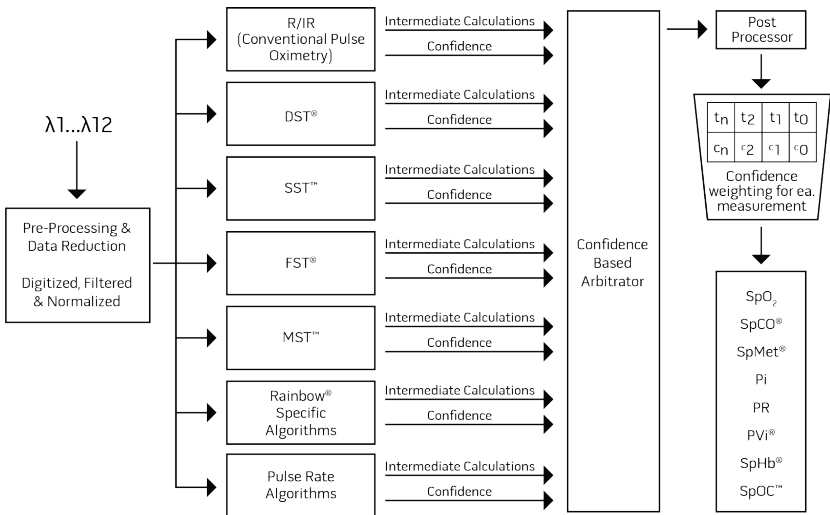

Masimo SET® DST

This figure is for conceptual purposes only.

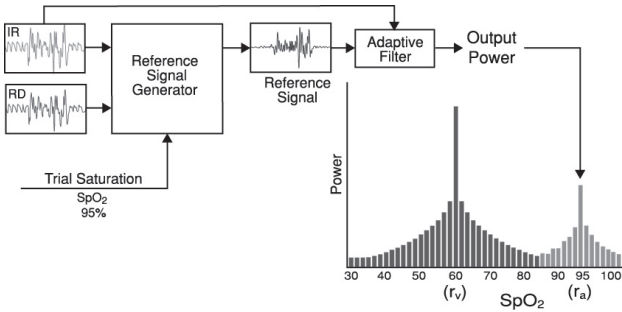

General Description for Oxygen Saturation (SpO₂)

Pulse oximetry is governed by the following principles:

1. Oxyhemoglobin (oxygenated blood) and deoxyhemoglobin (non-oxygenated blood) differ in their absorption of red and infrared light (spectrophotometry).
2. The amount of arterial blood in tissue changes with your pulse (photoplethysmography). Therefore, the amount of light absorbed by the varying quantities of arterial blood changes as well.

Successful Monitoring for SpO₂, PR and Pi

Stability of the SpO₂ readings may be a good indicator of signal validity. Although stability is a relative term, experience will provide a good feeling for changes that are artifactual or physiological and the speed, timing, and behavior of each.

The stability of the readings over time is affected by the averaging mode being used. The longer the averaging time, the more stable the readings tend to become. This is due to a dampened response as the signal is averaged over a longer period of time than during shorter averaging times. However, longer averaging times delay the response of the oximeter and reduce the measured variations of SpO₂ and pulse rate.

Functional Oxygen Saturation (SpO₂)

The Rad-97 is calibrated to measure and display functional oxygen saturation (SpO₂): the amount of oxyhemoglobin expressed as a percentage of the hemoglobin that is available to transport oxygen.

Note: Dyshemoglobins are not capable of transporting oxygen, but are recognized as oxygenated hemoglobins by conventional pulse oximetry.

General Description for Pulse Rate (PR)

Pulse rate (PR), measured in beats per minute (BPM) is based on the optical detection of peripheral flow pulse.

General Description for Perfusion Index (Pi)

The Perfusion Index (Pi) is the ratio of the pulsatile blood flow to the non-pulsatile or static blood in peripheral tissue. Pi thus represents a noninvasive measure of peripheral perfusion that can be continuously and noninvasively obtained from a pulse oximeter.

General Description for Pleth Variability Index (PVi)

The Pleth Variability Index (PVi) is a measure of the dynamic changes in the Perfusion Index (Pi) that occur during the respiratory cycle. The calculation is accomplished by measuring changes in Pi over a time interval where one or more complete respiratory cycles have occurred. PVi is displayed as a percentage (0-100%).

PVi may show changes that reflect physiological factors such as vascular tone, circulating blood volume, and intrathoracic pressure excursions.

The utility of PVi has been evaluated in clinical studies [1-11]. Technical and clinical factors that may affect PVi include probe malposition, probe site, patient motion, skin incision, spontaneous breathing activity, lung compliance, open pericardium, use of vasopressors or vasodilators, low perfusion index, subject age, arrhythmias, left or right heart failure, and tidal volume [12-14].

Citations for Pleth Variability Index (PVi)

1. Cannesson M., Desebbe O., Rosamel P., Delannoy B., Robin J., Bastien O., Lehot J.J. *Pleth Variability Index to Monitor the Respiratory Variations in the Pulse Oximeter Plethysmographic Waveform Amplitude and Predict Fluid Responsiveness in the Operating Theatre.* *Br J Anaesth.* 2008 Aug; 101(2):200-6.
2. Forget P, Lois F, de Kock M. *Goal-Directed Fluid Management Based on the Pulse Oximeter-Derived Pleth Variability Index Reduces Lactate Levels and Improves Fluid Management.* *Anesth Analg.* 2010 Oct; 111(4):910-4.
3. Zimmermann M., Feibicke T., Keyl C., Prasser C., Moritz S., Graf B.M., Wiesenack C. *Accuracy of Stroke Volume Variation Compared with Pleth Variability Index to Predict Fluid Responsiveness in Mechanically Ventilated Patients Undergoing Major Surgery.* *Eur J Anaesthesiol.* 2010 Jun; 27(6):555-61.
4. Desebbe O, Boucau C, Farhat F, Bastien O, Lehot JJ, Cannesson M. *The Ability of Pleth Variability Index to Predict the Hemodynamic Effects of Positive End-Expiratory Pressure in Mechanically Ventilated Patients under General Anesthesia.* 2010 Mar 1; 110(3):792-8.
5. Tsuchiya M., Yamada T., Asada A. *Pleth Variability Index Predicts Hypotension During Anesthesia Induction.* *Acta Anaesthesiol Scand.* 2010 May; 54(5):596-602.
6. Loupec T., Nanadoumgar H., Frasca D., Petitpas F., Laksiri L., Baudouin D., Debaene B., Dahyot-Fizelier C., Mimoz O. *Pleth Variability Index Predicts Fluid Responsiveness in Critically Ill Patients.* *Crit Care Med.* 2011 Feb; 39(2):294-9.

7. Fu Q., Mi W.D., Zhang H. Stroke Volume Variation and Pleth Variability Index to Predict Fluid Responsiveness during Resection of Primary Retroperitoneal Tumors in Hans Chinese. *Biosci Trends*. 2012 Feb; 6(1):38-43.
8. Haas S., Trepte C., Hinteregger M., Fahje R., Sill B., Herich L., Reuter D.A. J. Prediction of Volume Responsiveness using Pleth Variability Index in Patients Undergoing Cardiac Surgery after Cardiopulmonary Bypass. *Anesth*. 2012 Oct; 26(5):696-701.
9. Byon H.J., Lim C.W., Lee J.H., Park Y. H., Kim H.S., Kim C.S., Kim J.T. Br. J. Prediction of fluid Responsiveness in Mechanically Ventilated Children Undergoing Neurosurgery. *Anaesth* 2013 Apr; 110(4):586-91.
10. Feissel M., Kalakhy R., Banwarth P., Badie J., Pavon A., Faller J.P., Quenot J.P. Plethysmographic Variation Index Predicts Fluid Responsiveness in Ventilated Patients in the Early Phase of Septic Shock in the Emergency Department: A Pilot Study. *J Crit Care*. 2013 Oct; 28(5):634-9.
11. Yu Y., Dong J., Xu Z., Shen H., Zheng J. Pleth Variability Index-Directed Fluid Management in Abdominal Surgery under Combined General and Epidural Anesthesia. *J Clin Monit Comput*. 2014 Feb 21.
12. Desgranges F.P., Desebbe O., Ghazouani A., Gilbert K., Keller G., Chiari P., Robin J., Bastien O., Lehot J.J., Cannesson M. Br. J. *Anaesth* 2011 Sep; 107(3):329-35.
13. Cannesson M. Arterial pressure variation and goal-directed fluid therapy. *J Cardiothorac Vasc Anesth*. 2010 Jun; 24(3):487-97.
14. Takeyama M, Matsunaga A, Kakihana Y, Masuda M, Kuniyoshi T, Kanmura Y. Impact of Skin Incision on the Pleth Variability Index. *J Clin Monit Comput* 2011 Aug; 25(4):215-21.

Signal IQ

The Signal IQ provides an indicator of the assessment of the confidence in the displayed SpO₂ value. The SpO₂ SIQ can also be used to identify the occurrence of a patient's pulse.

With motion, the plethysmographic waveform is often distorted and may be obscured by noise artifact. Shown as a vertical line, the SpO₂ SIQ coincides with the peak of an arterial pulsation. Even with a plethysmographic waveform obscured by artifact, the Signal IQ identifies the timing that the algorithms have determined for the arterial pulsation. The pulse tone (when enabled) coincides with the vertical line of the SpO₂ SIQ.

The height of the vertical line of the SpO₂ SIQ provides an assessment of the confidence in the measurement displayed. A high vertical bar indicates higher confidence in the measurement. A small vertical bar indicates lower confidence in the displayed measurement. When the Signal IQ is very low, this suggests that the accuracy of the displayed measurement may be compromised. See **About the Status Bar** on page 49.

rainbow Pulse CO-Oximetry Technology

rainbow Pulse CO-Oximetry technology is governed by the following principles:

1. Oxyhemoglobin (oxygenated blood), deoxyhemoglobin (non-oxygenated blood), carboxyhemoglobin (blood with carbon monoxide content), methemoglobin (blood with oxidized hemoglobin) and blood plasma constituents differ in their absorption of visible and infrared light (using spectrophotometry).

- The amount of arterial blood in tissue changes with pulse (photoplethysmography). Therefore, the amount of light absorbed by the varying quantities of arterial blood changes as well.

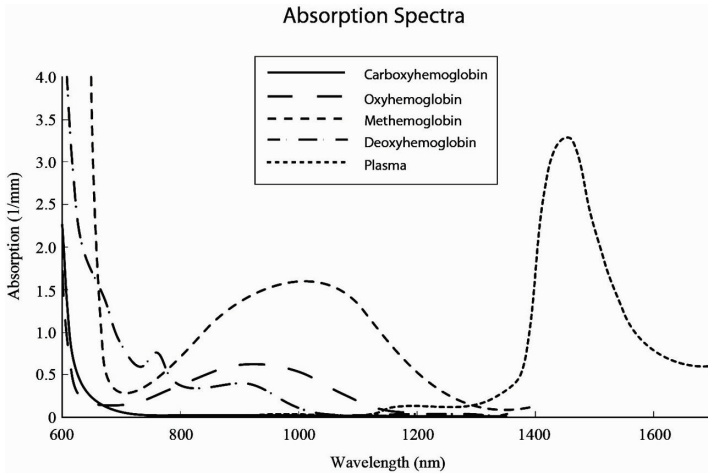

The Rad-97 uses a multi-wavelength sensor to distinguish between oxygenated blood, deoxygenated blood, blood with carbon monoxide, oxidized blood and blood plasma.

The Rad-97 utilizes a sensor with various light-emitting diodes (LEDs) that pass light through the site to a diode (detector). Signal data is obtained by passing various visible and infrared lights (LEDs, 500 to 1400nm) through a capillary bed (for example, a fingertip, a hand, a foot) and measuring changes in light absorption during the blood pulsatile cycle. This information may be useful to clinicians. The maximum radiant power of the strongest light is rated at ≤ 25 mW. The detector receives the light, converts it into an electronic signal and sends it to the Rad-97 for calculation.

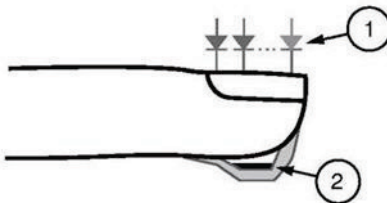

- Light Emitting Diodes (LEDs)
(7 + wavelengths)
- Detector

Once Rad-97 receives the signal from the sensor, it utilizes proprietary algorithms to calculate the patient's functional oxygen saturation (SpO₂ [%]), blood levels of carboxyhemoglobin saturation (SpCO [%]), methemoglobin saturation (SpMet [%]), total hemoglobin concentration (SpHb [g/dL]) and pulse rate (PR). The SpCO, SpMet and SpHb measurements rely on a multi-wavelength calibration equation to quantify the percentage of carbon monoxide and methemoglobin and the concentration of total hemoglobin in arterial blood. Maximum skin-sensor interface temperature was tested to be less than 41° C (106° F) in a minimum ambient temperature of 35° C (95° F). The tests were conducted with sensors operating at reasonable worst case power.

Pulse CO-Oximetry vs. Drawn Whole Blood Measurements

When SpO₂, SpCO, SpMet, and SpHb measurements obtained from the Rad-97 (noninvasive) are compared to drawn whole blood (invasive) measurements by blood gas and/or laboratory CO-Oximetry methods, caution should be taken when evaluating and interpreting the results.

The blood gas and/or laboratory CO-Oximetry measurements may differ from the SpO₂, SpCO, SpMet, SpHb, and SpOC measurements of the Rad-97. Any comparisons should be simultaneous, meaning the measurement on the device should be noted at the exact time that blood is drawn.

In the case of SpO₂, different results are usually obtained from the arterial blood gas sample if the calculated measurement is not appropriately corrected for the effects of variables that shift the relationship between the partial pressure of oxygen (pO₂) and saturation, such as: pH, temperature, the partial pressure of carbon dioxide (pCO₂), 2,3-DPG, and fetal hemoglobin.

In the case of SpCO, different results are also expected if the level of methemoglobin (MetHb) in the blood gas sample is abnormal (greater than 2% for MetHb).

In the case of SpHb, variation in hemoglobin measurements may be profound and may be affected by sampling technique as well as the patient's physiological conditions. Any results exhibiting inconsistency with the patient's clinical status should be repeated and/or supplemented with additional test data. As with most hemoglobin tests, a laboratory blood sample should be analyzed prior to clinical decision making.

High levels of bilirubin may cause erroneous SpO₂, SpMet, SpCO, and SpHb readings. As blood samples are usually taken over a period of 20 seconds (the time it takes to draw the blood) a meaningful comparison can only be achieved if the oxygen saturation (SaO₂), levels of carboxyhemoglobin (COHb), and MetHb of the patient are stable and not changing over the period of time that the blood gas sample is taken. Subsequently, blood gas and laboratory CO-Oximetry measurements of SpO₂, SpCO, SpMet, SpHb, and SpOC may vary with the rapid administration of fluids and in procedures such as dialysis. Additionally, drawn whole blood testing can be affected by sample handling methods and time elapsed between blood draw and sample testing.

Measurements with Low Signal IQ should not be compared to laboratory measurements.

General Description for Total Hemoglobin (SpHb)

Pulse CO-Oximetry is a continuous and noninvasive method of measuring the levels of total hemoglobin (SpHb) in arterial blood. It relies on the same principles of pulse oximetry to make its SpHb measurement.

Successful Monitoring for SpHb

A stable SpHb reading is associated with correct sensor placement, small physiological changes during the measurement and acceptable levels of arterial perfusion at the measurement site. Physiological changes at the measurement site are mainly caused by fluctuations in the oxygen saturation, blood concentration and perfusion. See **Safety Information, Warnings and Cautions** on page 13 and **Troubleshooting Measurements** on page 137.

General Description for Total Arterial Oxygen Content (CaO₂)

Oxygen (O₂) is carried in the blood in two forms, either dissolved in plasma or combined with hemoglobin. The amount of oxygen in the arterial blood is termed the oxygen content (CaO₂) and is measured in units of ml O₂/dL blood. One gram of hemoglobin (Hb) can carry 1.34 ml of oxygen, whereas 100 ml of blood plasma may carry approximately 0.3 ml of oxygen*. The oxygen content is determined mathematically as:

$$CaO_2 = 1.34 (ml O_2/g) \times Hb (g/dL) \times HbO_2 + PaO_2 (mmHg) \times 0.003 (ml O_2/dL/mmHg)$$

Where HbO₂ is the fractional arterial oxygen saturation and PaO₂ is the partial pressure of arterial oxygen.

For typical PaO₂ values, the second part of the above equation is approximately 0.3 ml O₂/dL based on PaO₂ being approximately 100 mmHg. Furthermore, for typical carboxyhemoglobin and methemoglobin levels, the functional saturation (SpO₂) as measured by a pulse oximeter is given by:

$$SpO_2 = 1.02 \times HbO_2$$

*Martin, Laurence. *All You Really Need to Know to Interpret Arterial Blood Gases, Second Edition*. New York: Lippincott Williams & Wilkins, 1999.

General Description for SpOC

The above approximations result in the following reduced equation for oxygen content via the Pulse CO-Oximeter:

$$SpOC (ml/dL^*) = 1.31 (ml O_2/g) \times SpHb (g/dL) \times SpO_2 + 0.3 (ml O_2/dL)$$

*When ml O₂/g Hb is multiplied by g/dL of SpHb, the gram unit in the denominator of ml/g cancels the gram unit in the numerator of g/dL resulting in ml/dL (ml of oxygen in one dL of blood) as the unit of measure for SpOC. See **Safety Information, Warnings and Cautions** on page 13.

General Description for Carboxyhemoglobin (SpCO)

Pulse CO-Oximetry is a continuous and noninvasive method of measuring the levels of carboxyhemoglobin saturation (SpCO) in arterial blood. It relies on the same basic principles of pulse oximetry (spectrophotometry) to make its SpCO measurement.

The measurement is obtained by placing a sensor on a patient, usually on the fingertip for adults and the hand or foot for infants. The sensor connects either directly to the Pulse CO-Oximetry device or through a device patient cable.

The sensor collects signal data from the patient and sends it to the device. The device displays the calculated data as percentage value for the SpCO, which reflect blood levels of carbon monoxide bound to hemoglobin.

Successful Monitoring for SpCO

A stable SpCO reading is associated with correct sensor placement, small physiological changes during the measurement and acceptable levels of arterial perfusion in the patient's fingertip (measurement site). Physiological changes at the measurement site are mainly caused by fluctuations in the oxygen saturation, blood concentration and perfusion.

General Description for Methemoglobin (SpMet)

Pulse CO-Oximetry is a continuous and noninvasive method of measuring the levels of methemoglobin saturation (SpMet) in arterial blood. It relies on the same basic principles of pulse oximetry (spectrophotometry) to make its SpMet measurement.

The measurement is obtained by placing a sensor on a patient, usually on the fingertip for adults and the hand or foot for infants. The sensor connects either directly to the Pulse CO-Oximetry device or through a patient cable.

The sensor collects signal data from the patient and sends it to the device. The device displays the calculated data as percentage value for the SpMet.

Successful Monitoring for SpMet

A stable SpMet reading is associated with correct sensor placement, small physiological changes during the measurement and acceptable levels of arterial perfusion in the patient's fingertip (measurement site).

Physiological changes at the measurement site are mainly caused by fluctuations in the oxygen saturation, blood concentration and perfusion. See **Safety Information, Warnings and Cautions** on page 13.

General Description for Respiration Rate (RRp)

RRp is currently not available in the U.S.A. and territories relying on FDA market clearance.

Respiration rate can be determined by the plethysmographic waveform (RRp). This method measures respirations per minute (rpm) based on plethysmographic amplitude changes that correspond to the respiratory cycle.

General Description for Oxygen Reserve Index (ORi)

ORi is currently not available in the U.S.A. and territories relying on FDA market clearance.

Pulse CO-Oximetry is a continuous and noninvasive method of measuring changes in oxygen states in hyperoxic conditions. It relies on the same principles of pulse oximetry to make its ORi measurement.

The measurement is taken by a sensor capable of measuring ORi, usually on the fingertip for adult or pediatric patients. The sensor connects directly to the Pulse CO-Oximeter or with a patient cable. The sensor collects signal data from the patient and sends it to the device. The device displays the processed data as an indicator of changes in oxygen states in hyperoxic conditions.

Successful Monitoring for ORi

A stable ORi reading is associated with correct sensor placement, small physiological changes during the measurement and acceptable levels of arterial perfusion at the measurement site. Physiological changes at the measurement site are mainly caused by fluctuations in the oxygen saturation, blood concentration and perfusion. See **Safety Information, Warnings and Cautions** on page 13 and **Troubleshooting Measurements** on page 137.

SpCO, SpMet, and SpHb Measurements During Patient Motion

The Rad-97 displays measurements of SpCO, SpMet, and SpHb during patient motion. However, because of the changes in the physiological parameters such as blood volume, arterial-venous coupling, etc. that occur during patient motion, the accuracy of such measurements may not be reliable during excessive motion. In this case, the measurement value for SpCO, SpMet, or SpHb displays as dashes (---) and a message (*Low SpCO SIQ, Low SpMet SIQ, or Low SpHb SIQ*) displays to alert the clinician that the device does not have confidence in the value due to poor signal quality caused by excessive motion or other signal interference.

rainbow Acoustic Monitoring™ (RAM™)

Note: This feature is currently available on Rad-97 devices only.

rainbow Acoustic Monitoring (RAM) continuously measures a patient's respiration rate based on airflow sounds generated in the upper airway. The Acoustic Sensor, which is applied on the patient's neck, translates airflow sounds generated in the upper airway to an electrical signal that can be processed to produce a respiration rate, measured as breaths per minute.

Respiratory sounds include sounds related to respiration such as breath sounds (during inspiration and expiration), adventitious sounds, cough sounds, snoring sounds, sneezing sounds, and sounds from the respiratory muscles [1].

These respiratory sounds often have different characteristics depending on the location of recording [2] and they originate in the large airways where air velocity and air turbulence induce vibration in the airway wall. These vibrations are transmitted, for example, through

the lung tissue, thoracic wall and trachea to the surface where they may be heard with the aid of a stethoscope, a microphone or more sophisticated devices.

rainbow Acoustic Monitoring Architecture

The following figure illustrates how a respiratory sound produced by a patient can be turned into a numerical measurement that corresponds to a respiratory parameter.

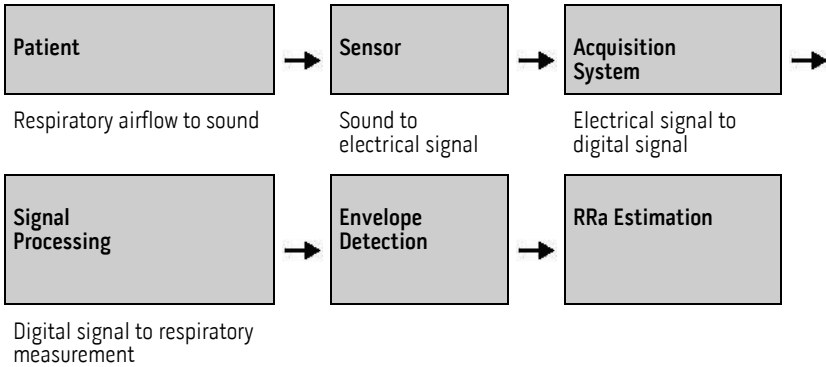

Patient

The generation of respiratory sounds is primarily related to turbulent respiratory airflow in upper airways. Sound pressure waves within the airway gas and airway wall motion contribute to the vibrations that reach the body surface and are recorded as respiratory sounds.

Although the spectral shape of respiratory sounds varies widely from person to person, it is often reproducible within the same person, likely reflecting the strong influence of individual airway anatomy [2-6].

Sensor

The sensor captures respiratory sounds (and other biological sounds) much like a microphone does. When subjected to a mechanical strain, (e.g., surface vibrations generated during breathing), the sensor becomes electrically polarized.

The degree of polarization is proportional to the applied strain. The output of the sensor is an electric signal that includes a sound signal that is modulated by inspiratory and expiratory phases of the respiratory cycle.

Acquisition System

The acquisition system converts the electric signal provided by the sensor into a digital signal. This format allows the signal to be processed by a computing device.

Signal Processing

The digital signal produced by the acquisition system is converted into a measurement that corresponds to the respiratory parameter of interest. As shown in the previous figure, this can be performed by, for example, determining the digital signal envelope or outline which in turn may be utilized to determine the respiratory rate. In this way, a real-time, continuous breath rate parameter can be obtained and displayed on a monitor which, in many cases, may be real-time and continuous.

The respiratory cycle envelope signal processing principle is similar to methods that sample airway gasses and subsequently determine a respiratory rate.

Citations

- [1] A.R.A. Sovijärvi, F. Dalmaso, J. Vanderschool, L.P. Malmberg, G. Righini, S.A.T. Stoneman. *Definition of terms for applications of respiratory sounds. Eur Respir Rev* 2000; 10:77, 597-610.
- [2] Z. Moussavi. *Fundamentals of respiratory sounds analysis. Synthesis lectures on biomedical engineering #8. Morgan & Claypool Publishers, 2006.*
- [3] Olsen, et al. *Mechanisms of lung sound generation. Semin Respir Med* 1985; 6: 171-179.
- [4] Pastercamp H, Kraman SS, Wodicka GR. *Respiratory sounds – Advances beyond the stethoscope. Am J Respir Crit Care Med* 1977; 156: 974-987.
- [5] Gavriely N, Cugell DW. *Airflow effects on amplitude and spectral content of normal breath sounds. J Appl Physiol* 1996; 80: 5-13.
- [6] Gavriely N, Palti Y, Alroy G. *Spectral characteristics of normal breath sounds. J Appl Physiol* 1981; 50: 307-314.

Chapter 2: Description

This chapter contains the description of the Rad-97 physical features.

General System Description

The Rad-97 system includes the following:

- Rad-97 Device
- AC Power Cord
- Patient Cable
- Sensor

For a complete list of compatible sensors and cables, visit <http://www.masimo.com>.

Features

Front View

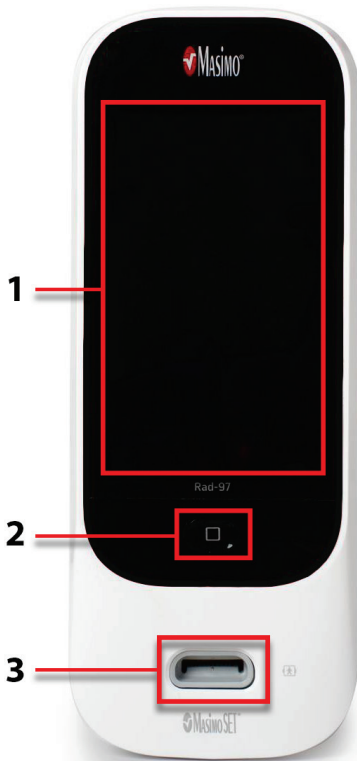

1. Display and Touchscreen

Provides a user interface to view and change settings.

2. Home Button

Provides a multipurpose user interface that allows for navigation to the home screen as well as turning the device on and off.

3. Patient Cable Connector

Provides a connection to a patient cable or sensor.



4. NIBP Nib*

Allows connection to a cuff for blood pressure measurements.

*Optional feature.

Back View

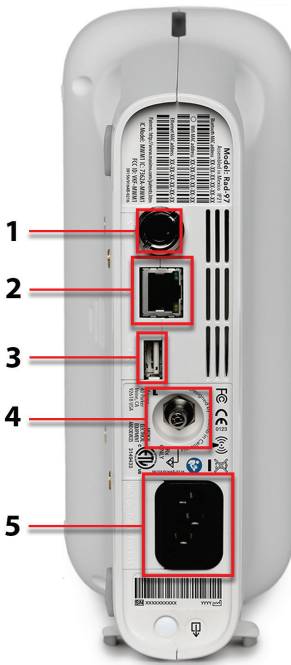

1. Nurse Call Connector

Allows connection to a Nurse Call system.

Caution: To ensure patient electrical isolation, all external device connections to the Analog Output/Nurse Call connectors must be IEC 60950-1, IEC 60601-1, or UL 1069 compliant.

See *Nurse Call Connection* on page 41.

2. Ethernet

Allows network connection to Rad-97 using an RJ-45 cable.

3. USB

Provides USB 2.0 connectivity.

4. Equipotential Ground Connector

Provides optional functional earthing for Rad-97 to eliminate potential differences between the earth connections for Rad-97 and another medical device. The use of the Equipotential Ground Connector should be in accordance with IEC 60601-1.

5. Power Entry Module

Provides connection to an AC power cord.

Note: Always connect the Rad-97 to the mains power for continuous operation and/ or battery recharging.

Note: Use the power cord as the means to disconnect the device from AC power. To disconnect the device from AC power, first disconnect the power cord from the power outlet, rather than from the device.

Side and Top Views

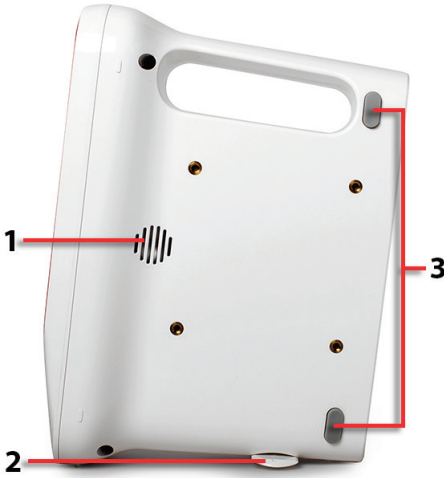

1. Speaker

The speaker provides audio alarms. Care should be taken not to cover the speaker.

2. Swivel Foot

Provides stability when placing Rad-97 on a surface in a vertical position.

3. Foot Pads

Provides physical support to Rad-97 when placed on a surface in a horizontal position.



4. System Status Light

Provides an indication of alarm status. See *About the System Status Light* on page 56.

Chapter 3: Setting Up

This chapter contains information about setting up Rad-97 before use.

Unpacking and Inspection

To unpack and inspect the Rad-97:

1. Remove the Rad-97 from the shipping carton and examine it for signs of shipping damage.
2. Check all materials against the packing list. Save all packing materials, invoice and bill of lading. These may be required to process a claim with the carrier.
3. If anything is missing or damaged, contact the Masimo Technical Service Department. See **Return Procedure** on page 173.

Preparation for Use

Prior to setting up the Rad-97 for monitoring, perform the following steps:

1. Confirm that you have all system components:
 - Rad-97 Device
 - AC Power Cord
 - Patient Cable
 - Sensor
2. Read the **Safety Information, Warnings and Cautions** on page 13.
3. Setup the Rad-97 according to the directions provided in this Operator's Manual.

Guidelines for Setting Up

When setting up Rad-97, follow these guidelines:

1. Place on a stable, hard, flat, dry surface near the patient.
Caution: Do not place the Rad-97 where the controls can be changed by the patient.
Note: If placed in a vertical position, rotate the swivel foot at the base of the device as shown in **Side and Top Views** on page 38 for stability.
2. Maintain a minimum of three (3) centimeters (approximately one [1] inch) of free space around Rad-97.
3. Ensure that the Speaker is not covered to avoid a muffled alarm sound.
4. Charge Rad-97's battery fully before use. See **Initial Battery Charging** on page 41.
5. Rad-97 should not be operated outside the environmental conditions listed in the specifications section. See **Environmental** on page 152.

Powering the Rad-97 ON and OFF

To Power ON Rad-97

1. Press and hold the Home Button for more than two (2) seconds, until one (1) audible tone sounds.

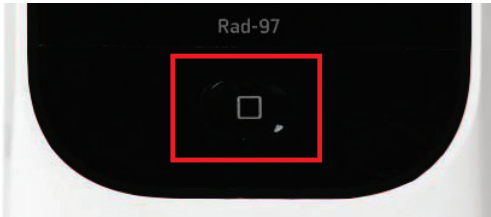

2. The Home Button will illuminate Green and the Rad-97 will power on.

To Power OFF Rad-97

When powering off the Rad-97, the device remembers the last settings if the Power on Profile is set to *Previous Profile*. See **Access Control** on page 94. The device also remembers the *Device Mode* when turned off, and will turn back on in that mode.

1. Press and hold the Home Button for more than 8 seconds, until two (2) audible tones sound.
2. The Home Button will flash Orange.
3. The Rad-97 will power down and turn off.



Initial Battery Charging

Before use, the Rad-97 battery must be charged completely.

To charge Rad-97

1. Plug the AC power cord into the power entry module. Make sure it is securely plugged in.
2. Plug the AC power cord into an AC power source.
3. Verify that the battery is charging:
 - When Rad-97 is ON and charging, the AC Power Indicator lightning bolt icon will appear on the screen.



- When Rad-97 is OFF and charging, the Home button will illuminate Orange.
4. When the battery is fully charged:
 - When Rad-97 is ON and fully charged, the AC Power Indicator will change to a plug icon.



Touch the AC Power Indicator icon to view battery charge details. See **Rad-97 Battery** on page 93. For additional information, see **Battery Operation and Maintenance** on page 172.

Nurse Call Connection

To connect to a Nurse Call System

1. Identify the Nurse Call connection end (1/4 inch round male connector) of the cable.
2. Insert the Nurse Call cable connector securely into the compatible port (1/4 inch round female connector) on the rear of the Rad-97. See **Back View** on page 37.
3. Depending on the connection type of the Nurse Call System, it may be necessary to orient the other end of the Nurse Call connection cable to fit correctly into the system connection.
4. It may be necessary to configure the settings of the Nurse Call output. See **Device Output** on page 96 and **Nurse Call Setting Connections** on page 167 for additional information.

Attach NIBP Cuff

1. Connect the cuff to the patient hose.
2. Connect the opposite end of the patient hose to the NIBP Nib located on the front of Rad-97. See **Chapter 6: Noninvasive Blood Pressure (NIBP)** on page 109.

Masimo Kite

Masimo Kite Software Application is a passive monitoring interface to Point-of-Care (POC) Masimo medical devices (Rad-97 for example) that co-exist under the same Wi-Fi network. Kite remotely displays system and parameter status reported by the POC device on a separate monitor.

Rad-97 must be on the same network as Kite.

Note: If the device is not on the same network, it can be added, but Kite will not be able to connect it to view the parameters monitored by that device until both Kite and the device are connected to the same network.

To add Rad-97 to Kite to view parameter status, refer to the Masimo Kite Software Application Operator's Manual.

Third-Party Devices

Third-party devices can be connected to Rad-97 through Bluetooth communication. For more information, including how to connect a device to Rad-97, see **Chapter 8: Third-Party Devices** on page 121.

Chapter 4: Operation

The information in this chapter assumes that Rad-97 is set up and ready for use. This chapter provides necessary information for proper operation of the device. Do not operate Rad-97 without completely reading and understanding these instructions.

Using the Touchscreen and Home Button

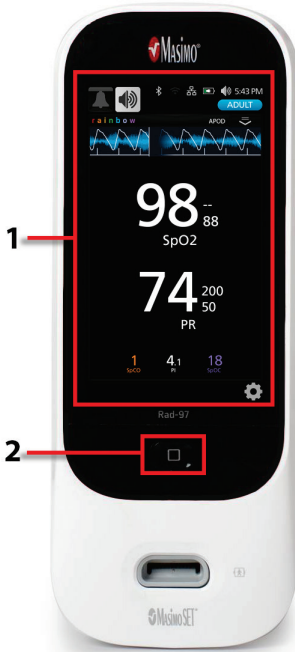

1. Main Screen

To access settings and other screens, touch a value or icon on the Display View. See **About the Main Screen** on page 48.

2. Home / Power button









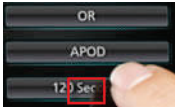

To return to the *Main Screen*, press the Home button.

The Home button is also used to power the device ON and OFF. See **Powering the Rad-97 ON and OFF** on page 40.

The Home Button changes color depending on the selected profile. See **Profiles Overview** on page 103.

Using the Touchscreen Interface

Using the gestures described below, the user is able to customize the viewing experience, including displaying the highest priority parameters and measurements. Feature navigation availability is dependent on which medical devices are connected to Rad-97.

Action	Illustration	Example	Description
Touch			Touch and release. Action performed once finger is released.
Touch and Hold			Touch and hold. Action performed once hold duration is reached. A notification is displayed.
Swipe (Touch and Move)			Touch, move (left, right, up or down), and release. Moves an object across the display.
Flick			Touch and quickly swipe (left, right, up or down), and release.
Pinch			Touch, move, and release via two touch points. Moving touch points apart zooms in, and moving them together zooms out.
Drag and Drop		See <i>Understanding Windows</i> on page 53.	Touch, hold, drag an object to desired position, and drop it by releasing.

Below is a list of all the different types of controls available on Rad-97 and the various ways to interact with each type of control.

Control	Applicable Actions	Description
Toggle	Touch and slide knob	<ul style="list-style-type: none"> Switches between toggle states
	Touch and slide left or right of toggle	<ul style="list-style-type: none"> Quickly moves knob left or right
Labeled Toggle	Touch and slide knob	<ul style="list-style-type: none"> Switches between toggle states
	Touch and slide left or right of toggle	<ul style="list-style-type: none"> Quickly moves knob left or right
	Touch label	<ul style="list-style-type: none"> Quickly moves knob left or right
Spinner	Touch center (focused) tile	<ul style="list-style-type: none"> When closed, expands spinner When open, collapses spinner
	Swipe up or down	<ul style="list-style-type: none"> When open, scrolls through spinner tiles
	Touch unfocused tile	<ul style="list-style-type: none"> When open, scrolls tile into center (focused) position
	Touch anywhere outside spinner	<ul style="list-style-type: none"> When open, collapses spinner
Slider	Touch and slide knob	<ul style="list-style-type: none"> Moves knob
	Press anywhere along slider path	<ul style="list-style-type: none"> Quickly moves knob to tap position
Slider Spinner	Touch and slide knob	<ul style="list-style-type: none"> Moves knob
	Touch anywhere along slider path	<ul style="list-style-type: none"> Quickly moves knob to tap position
	Touch center (focused) tile	<ul style="list-style-type: none"> When closed, expands spinner When open, collapses spinner
	Swipe up/down	<ul style="list-style-type: none"> When open, scrolls through spinner tiles
	Touch unfocused tile	<ul style="list-style-type: none"> When open, scrolls tile into center (focused) position

Control	Applicable Actions	Description
	Touch anywhere outside spinner	<ul style="list-style-type: none"> When open, collapses spinner
Button	Touch	<ul style="list-style-type: none"> Performs action (as defined by the button description)
Icon Menu	Touch tile	<ul style="list-style-type: none"> Opens menu specified by tile
	Swipe left or right (anywhere)	<ul style="list-style-type: none"> Scrolls icons left or right
	Touch bottom indicator icon	<ul style="list-style-type: none"> Quickly centers tile corresponding to indicator icon
Window	Touch parameter or measurement	<ul style="list-style-type: none"> When no parameter or measurement alarm is present, opens parameter or measurement menu When parameter or measurement alarm is present, silences parameter or measurement alarm
	Touch and hold	<ul style="list-style-type: none"> Enables parameter and measurement drag and drop
Well	Touch parameter or measurement	<ul style="list-style-type: none"> When no parameter or measurement alarm is present, opens parameter or measurement menu When parameter or measurement alarm is present, silences parameter or measurement alarm
	Touch and hold	<ul style="list-style-type: none"> Enables parameter and measurement drag and drop
Live Waveform	Swipe down	<ul style="list-style-type: none"> Separates pleth and acoustic waveforms
	Swipe up	<ul style="list-style-type: none"> Combines pleth and acoustic waveforms
Trend Line	Pinch in	<ul style="list-style-type: none"> Zooms out
	Pinch out	<ul style="list-style-type: none"> Zooms in
	Pan	<ul style="list-style-type: none"> Changes time range

Control	Applicable Actions	Description
	Touch y-axis	<ul style="list-style-type: none"> • Opens parameter or measurement trend menu
Trend Zoom	Touch '+'	<ul style="list-style-type: none"> • Increases time range
	Touch '-'	<ul style="list-style-type: none"> • Decreases time range
	Touch time label	<ul style="list-style-type: none"> • Resets time range to default
Alarm Silence icon	Touch	<ul style="list-style-type: none"> • Silences all alarms
Audio Pause icon	Touch	<ul style="list-style-type: none"> • Enables Audio Pause
Other Status Bar icons	Touch	<ul style="list-style-type: none"> • Opens relevant menu
Back Arrow	Touch	<ul style="list-style-type: none"> • Exits menu, abandons any changes

About the Main Screen

The *Main Screen* consists of different areas.

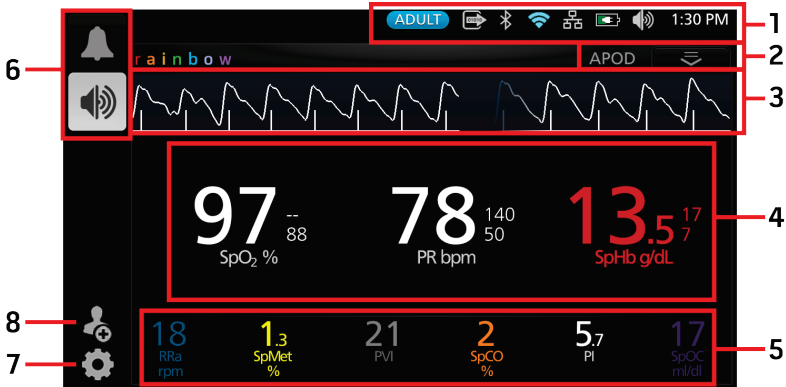

Ref.	Feature	Information
1	Status Bar	See <i>About the Status Bar</i> on page 49.
2	Action Menu	See <i>About the Action Menu</i> on page 51.
3	Waveform View	See <i>Waveform Mode</i> on page 79.
4	Parameter Display	See <i>Understanding Windows</i> on page 53.
5	Well	See <i>Understanding Windows</i> on page 53.
6	Alarm Silence	See <i>About Alarms</i> on page 124.
7	Main Menu	See <i>Accessing Main Menu Options</i> on page 57.
8	Patient Admit/Discharge	See <i>Patient Admit/Discharge</i> on page 101.

About the Status Bar

The *Status Bar* is visible at the top of the *Main Screen*.

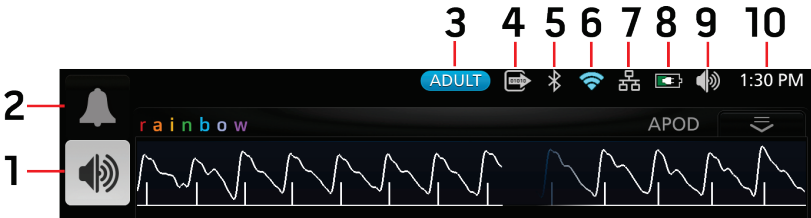



Ref.	Feature	Description
1	Audio Pause	Suspends all audible alarms and displays remaining Audio Pause Duration time when activated during an alarm event. Visual alarms are not impacted and will still display. See Audio Pause on page 126.
2	Alarm Silence	Displays alarm status and mutes all active audible alarms. See Silencing Alarms on page 125.
3	Profiles	Provides access to the <i>Profiles</i> screen. The example shown illustrates the current Profile is Adult, for an adult patient. See Chapter 5: Profiles on page 103.
4	Device Output	Provides access to the <i>Device Output</i> screen. See Device Output on page 96.
5	Bluetooth	Provides access to the <i>Bluetooth</i> screen. If this icon is visible, then Bluetooth connectivity has been enabled. See Bluetooth on page 92.
6	Wi-Fi	Provides access to the <i>Wi-Fi</i> screen. If this icon is visible, then Wi-Fi connectivity has been enabled. The icon itself also indicates the strength of the wireless signal. See Wi-Fi on page 92.
7	Ethernet	Provides access to the <i>Ethernet</i> screen. If this icon is visible, then Ethernet connectivity has been enabled. See Ethernet on page 91.

Ref.	Feature	Description
8	Rad-97 Battery Charge/AC Power Indicator	Displays charging status. Provides access to the <i>Battery</i> screen. The example shows that AC power is connected and the battery is currently charging. See AC Power Indicator on page 50 and Battery Charge Status Indicator on page 51.
9	Sounds	Provides access to the <i>Sounds</i> screen to adjust alarm and pulse tone volume. This icon does not indicate the actual volume level of the alarm and pulse tone. See Sounds on page 85.
10	Current Time	Displays the current time and provides access to the <i>Localization</i> screen, which contains settings related to local time, language, and geography. See Localization on page 87.

AC Power Indicator

Whenever Rad-97 is connected to an AC power source and ON, the AC Power Indicator icon will appear on the display as follows:

Icon	Status
	Battery is currently charging
	Battery is fully charged

Touch the AC Power Indicator icon to view battery charge details. See **Rad-97 Battery** on page 93.

Battery Charge Status Indicator



When unplugged from AC power, the Battery Charge Status Indicator icon provides a visual indication of the current battery charge condition.



When the battery charge reaches a low level:

- The Battery Charge Status Indicator icon will change color (Red).
- A "Low Battery" message appears and a medium priority alarm tone will sound with a Red border on the display. The system status light will flash Yellow.

Connect the battery to AC power to prevent the device from powering off and to charge the battery. When connected to power, the AC Power Indicator icon will be displayed.

Touch the Battery Charge Status Indicator icon to view battery details. See **Rad-97 Battery** on page 93.

About the Action Menu



To expand the *Action Menu*, select the arrow in the upper right corner of the window.

Note: After approximately 10 seconds without interaction, the *Action Menu* will retract.

The *Action Menu* allows quick access to the following settings directly from the *Main Screen*:

- **Sensitivity** - Selecting this option cycles through the available sensitivity modes: APOD, NORM and MAX. See **Sensitivity Modes Overview** on page 52.
- **Trend View** - Displays values in *Trend View*. See **Customizing Trend View** on page 54.
- **Numeric View** - Displays values in a standard grid view.

On NIBP models, the *Action Menu* provides access to the following settings:

- **Intervals** - Opens the intervals setting screen. See **Stat Interval NIBP Measurement** on page 114.

- **Auto** - Starts the automatic blood pressure check operation. See **Automatic Interval Measurement** on page 113.
- **Trend View** - Displays values in *Trend View*. See **Trends for NIBP** on page 82.
- **Numeric View** - Displays values in a standard grid view.

Sensitivity Modes Overview

Three sensitivity levels enable a clinician to tailor the response of Rad-97 to the needs of the particular patient situation. Sensitivity Modes are accessed through the *Action Menu*. See **About the Action Menu** on page 51.

The sensitivity levels are as follows:

- **NORM (Normal Sensitivity)**
NORM is the recommended sensitivity mode for patients who are experiencing some compromise in blood flow or perfusion. It is advisable for care areas where patients are observed frequently, such as an intensive care unit (ICU).
- **APOD® (Adaptive Probe Off Detection® Sensitivity)**
APOD is the recommended sensitivity mode for situations where there is a high probability of the sensor becoming detached. It is also the suggested mode for care areas where patients are not visually monitored continuously. This mode delivers enhanced protection against erroneous pulse rate and arterial oxygen saturation readings when a sensor becomes inadvertently detached from a patient due to excessive movement.
- **MAX (Maximum Sensitivity)**
MAX is the recommended sensitivity mode for patients with low perfusion or when a *low perfusion* message displays in APOD or NORM mode. MAX mode is not recommended for care areas where patients are not monitored visually, such as medical-surgical floors. It is designed to display data at the measuring site when the signal may be weak due to decreased perfusion. When a sensor becomes detached from a patient, it will have compromised protection against erroneous pulse rate and arterial saturation readings.

Understanding Windows

The following information describes how to customize the information viewed on the *Main Screen*.

Customizing Windows

Windows can be customized by expanding and minimizing parameters and measurements in both *Trend View* and *Numeric View*. When a parameter is minimized, it is only displayed in the Well with its Numeric Value and Parameter Label. When a parameter is expanded, it will be shown in the Parameter display with or without its trend, depending on *Trend View* setup. See **Customizing Trend View** on page 54.

To expand a parameter or measurement

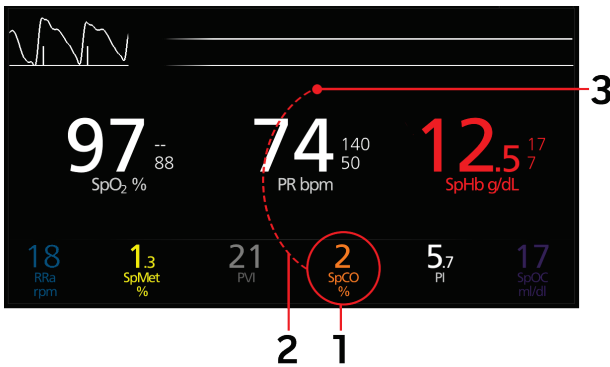

Order	Instruction
Step 1	Touch and hold the Numeric Value until it dims.
Step 2	Drag the Numeric Value over any Trend Display.
Step 3	Release the Numeric Value.

To minimize a parameter or measurement

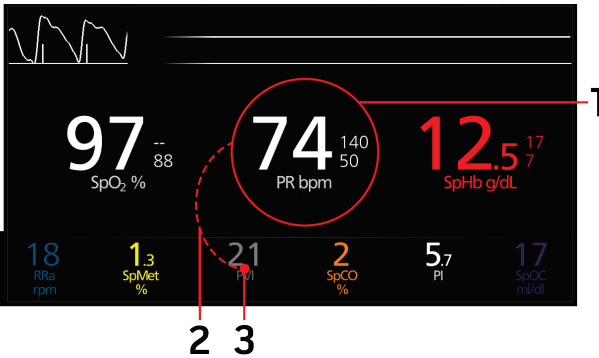

Order	Instruction
Step 1	Touch and hold the Numeric Value until it shrinks.
Step 2	Drag the Numeric Value to the Well.
Step 3	Release the Numeric Value.

Customizing Trend View

There are different ways to view trend information. The following is an example of trend information for SpO₂, PR, and Pi as they appear within the *Main Screen* with the device in the horizontal position:



In *Trend View*, a parameter or measurement is displayed as a graph of its values over time.

The following diagram and table describe key features of a parameter's trend display in *Trend View*.



Ref.	Feature	Description
1	Value Range	Indicates current range of the displayed parameter or measurement. Press to access the Trend Menu from which the minimum and maximum values in the range can be modified.
2	Trend Graph	Displays parameter measurement over a period of time. Zoom in and out of a Trend Graph by pinching out and in.
3	Numeric Value	Indicates current reading of the parameter or measurement.
4	Alarm Limits	Indicate high and low alarm limits for the parameter or measurement, if applicable.
5	Parameter or Measurement Label	Indicates the name of the parameter or measurement.

Data can be added to or removed from *Trend View* in the same manner as described in **Customizing Windows** on page 53. Data can be manipulated using the touchscreen as follows:

1. Swipe the trend view display left or right to scroll the *Trend View* data forward or backward in time.
2. Tap the *Trend View* in a specific spot to view the values at that time.
3. Touch the box in the lower right corner of the screen to change the time range of *Trend View* data displayed on the screen. Select from 0:10h (10 minutes) to 24:00h (24 hours).
4. Using a pinch gesture with two fingers, zoom in and out of the *Trend View* data displayed on the screen from 0:10h (10 minutes) to 24:00h (24 hours) in increments of 0:01h.

About the System Status Light

The System Status Light provides visual indications of alarms and system messages. The light will illuminate in different colors depending on the state of the device.

To locate the System Status Light, see **Side and Top Views** on page 38.

Light Status	Alarm Priority	Indication
None	None	System is off
Green	None	System is monitoring patient; no alarms.
Yellow	Low	<p>There is an active, low priority alarm.</p> <p>Examples of low priority alarms:</p> <ul style="list-style-type: none"> • No cable is connected. • Cable connected but there is no sensor connected to cable. • Sensor is off patient and has been acknowledged.
Flashing Yellow	Medium	<p>There is an active medium priority alarm.</p> <p>Example of a medium priority alarm:</p> <ul style="list-style-type: none"> • Device battery is low.
Flashing Red	High	<p>There is an active high priority alarm.</p> <p>Example of a high priority alarm:</p> <ul style="list-style-type: none"> • The sensor has come off of the patient.

Accessing Main Menu Options

To access Main Menu options, press the Main Menu icon in the bottom left corner of the touchscreen:



The Main Menu options are:



Parameter Settings

Displayed on devices without NIBP.

See *Parameter Settings* on page 60.



rainbow Parameter Settings

Displayed on devices with NIBP.

See *rainbow Parameter Settings* on page 59.



Noninvasive Blood Pressure Settings

See *Noninvasive Blood Pressure (NIBP) Settings* on page 80.



Additional Settings*

Displayed on devices without NIBP. Devices with NIBP display this icon under the rainbow Parameters Settings menu.

See *Additional Settings* on page 78.



Profiles*

See *Chapter 5: Profiles* on page 103.



Sounds

See *Sounds* on page 85.



Device Settings

See *Device Settings* on page 86.



About

See *About* on page 97.



3D Alarms*

Displayed on devices without NIBP. Devices with NIBP display this icon under the rainbow Parameters Settings menu.

See **3D Alarms** on page 128.



Trends*

See **Trends** on page 97.



Rad-97

This icon is displayed when the Rad-97 is in optional *Home* mode (when available), allowing device settings to be changed.

See **Home** on page 89.

* This icon is neither available nor displayed in the Main Menu when the device is in optional *Home* mode (when available). See **Home** on page 89.

Navigating the Main Menu

Once the Main Menu screen is displayed, users can access additional screens, information and settings. Swipe the screen left or right to pan through the menu icons. Touch the arrow icon to return to the *Main Screen*.

Note: Non-NIBP device used in the examples below.

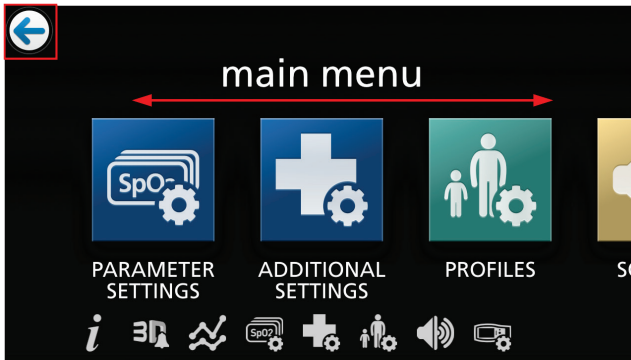

Icons at the bottom edge of the displayed menu screen correspond to the settings. Touch an icon to jump to the setting on the displayed menu screen.



Display Timeout

When viewing any of the menu screens, and no user interaction occurs within one (1) minute, the display times out and returns to the *Main Screen*.

Navigating Through Menus

When configuring settings, all changes must be confirmed by selecting *OK*. To cancel the changes, select *Cancel*.



Any screen requiring selection of option(s) will time out after one (1) minute of inactivity and return to the *Display View*.

To navigate to the previous screen, press the arrow  in the top left corner of the touchscreen.

To return to the *Main Screen*, press the Home Button  at any time.

rainbow Parameter Settings



On Rad-97, the *rainbow* menu allows the user to view and customize settings for rainbow parameters:



Parameter Settings

See ***Parameter Settings*** on page 60.



3D Alarms

See ***3D Alarms*** on page 128.



Additional Settings

See ***Additional Settings*** on page 78.

Parameter Settings



The following is an example of the Rad-97 *Parameter Settings* screen.

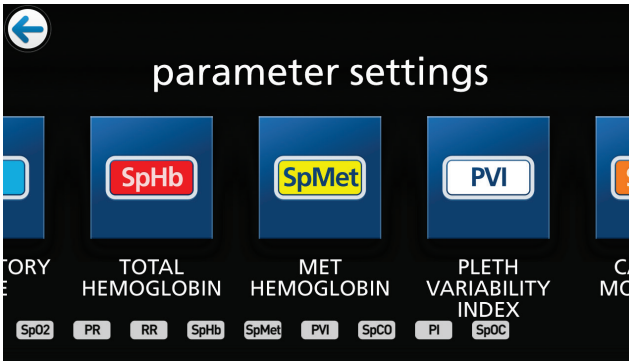

To access any of the available parameter setting screens:

1. From the *Parameter Settings* screen, to access the desired parameter, swipe the on-screen icons left or right.
2. Touch the icon of the desired parameter.

Parameter Settings include:

- See *SpO2 Settings* on page 62
- See *PR Settings* on page 64
- See *Pi Settings* on page 65
- See *PVi Settings* on page 66
- See *Respiration Rate (RR) Settings* on page 67
- See *SpHb Settings* on page 71
- See *SpOC Settings* on page 74
- See *SpMet Settings* on page 74
- See *SpCO Settings* on page 76
- See *ORi Settings* on page 77

In Vivo Adjustment Overview

In Vivo is currently not available in the U.S.A. and territories relying on FDA market clearance.

The In Vivo Adjustment feature lets clinicians manually adjust the displayed value(s) of one or more clinical parameters to match a corresponding laboratory reference during continuous trending. To remind clinicians that the feature is active, an offset value displays alongside the adjusted parameter value.

The In Vivo Adjustment feature for a parameter can be turned on by accessing the *In Vivo* screen in the *Settings* menu for that parameter. After enabling the feature, set an offset value. Once the feature is enabled, a positive or a negative offset value appears, as shown in the below illustration.

The In Vivo offset amount is set to zero when any of the following conditions occur:

- Cable or sensor is disconnected from device.
- Sensor goes off patient causing a sensor initialization to occur.
- Eight hours has elapsed since the In Vivo offset was activated.
- Restore of factory defaults.
- User turns off In Vivo.

Offset Value

When In Vivo Adjustment is activated for a specific parameter, the offset value appears beneath that specific parameter. A positive value means that the displayed parameter value has been increased (according to a laboratory reference value, as entered by a clinician) and a negative value means the displayed parameter value has been decreased (according to a laboratory reference value, as entered by a clinician).

In the example below, the displayed SpO₂ value of 96 takes into account an offset of -1.0, and the displayed SpHb value of 16.0 takes into account an offset of +0.4.

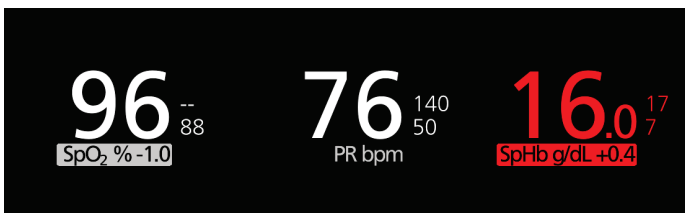

The In Vivo Adjustment feature can be set to *On* or *Off*. The factory default setting is *Off*. If set to *On*, the parameter value is adjusted and an offset value appears. The offset value is set by the user.

The feature applies to any of the following parameters:

- See *In Vivo for SpO₂* on page 64
- See *In Vivo for SpHb* on page 73
- See *In Vivo for SpCO* on page 76
- See *In Vivo for SpMet* on page 75

SpO2 Settings

Allows access to any of the following options:

SpO2 Alarms on page 62

Additional Settings for SpO2 on page 63

In Vivo for SpO2 on page 64

Trends on page 97

About Parameter Information on page 78

About Desat Index on page 128

SpO2 Alarms

From the *Alarms* screen, change any of the following options:

Options	Description	Alarm Priority	Factory Default Settings	User Configurable Settings
High Limit	High Limit is the upper threshold that triggers an alarm.	Medium	Off	2% to 99% in steps of 1%, or Off When set to Off, alarm is disabled
Low Limit	Low Limit is the lower threshold that triggers an alarm.	High	88%	1% to 98% in steps of 1%
Rapid Desat	Sets the Rapid Desat limit threshold to the selected amount below the Low Alarm Limit. When an SpO ₂ value falls below the Rapid Desat limit the audio and visual alarms are immediately triggered without respect to alarm delay.	NA	-10%	Off, -5%, or -10%
Alarm Delay	When an alarm condition is met, this feature delays the audible part of an alarm.	NA	15 seconds	0, 5, 10, or 15 seconds
Silence Duration	Sets the amount of time that the alarm is silenced.	NA	2 minutes	30 sec, 1 or 2 minutes

Options	Description	Alarm Priority	Factory Default Settings	User Configurable Settings
Adaptive Threshold Alarm (ATA)	ATA establishes patient-specific limit thresholds based upon the baseline value of the parameter. See Adaptive Threshold Alarm (ATA) Feature on page 127.	NA	Off	Off or On

Additional Settings for SpO2

From the *Additional Settings* screen, change any of the following options:

Options	Description	Factory Default Settings	User Configurable Settings
Averaging Time*	The length of time over which the system calculates the average of all data points.	8 seconds**	2-4, 4-6, 8, 10, 12, 14, or 16 seconds***
FastSat	See FastSat Overview on page 63.	Off	Off or On

* With FastSat the averaging time is dependent on the input signal.

** Defaults to 2-4 seconds when in Sleep Study mode. See **Sleep Study** on page 90.

*** For the 2 and 4 second settings the averaging time may range from 2-4 and 4-6 seconds, respectively.

FastSat Overview

FastSat enables rapid tracking of arterial oxygen saturation changes. Arterial oxygen saturation data is averaged using pulse oximeter averaging algorithms to smooth the trend.

When Rad-97 is set to FastSat *On*, the averaging algorithm evaluates all saturation values, providing an averaged saturation value that is a better representation of the patient's current oxygenation status. With FastSat set to *On*, the averaging time is dependent on the input signal.

In Vivo for SpO2

In Vivo is currently not available in the U.S.A. and territories relying on FDA market clearance.

From the *In Vivo* screen, change any of the following options:

Options	Description	Factory Default Settings	User Configurable Settings
Enabled	See <i>In Vivo Adjustment Overview</i> on page 61.	Off	On or Off
Offset Amount	See <i>In Vivo Adjustment Overview</i> on page 61.	0.0 when turned on	-6.0% to +6.0%, in steps of 0.1%

PR Settings

From the *PR Settings* screen, change any of the following options:

PR Alarms on page 64

Trends on page 97

About Parameter Information on page 78

PR Alarms

From the *PR Alarms* screen, change any of the following options:

Options	Description	Alarm Priority	Factory Default Settings	User Configurable Settings
High Limit	High Limit is the upper threshold that triggers an alarm.	High	140 bpm	35 bpm to 235 bpm, in steps of 5 bpm
Low Limit	Low Limit is the lower threshold that triggers an alarm.	High	50 bpm	30 bpm to 230 bpm, in steps of 5 bpm
Silence Duration	Sets the amount of time that the alarm is silenced.	NA	2 minutes	30 sec, 1, 2 or 5 minutes

Pi Settings

From the *Pi Settings* screen, access any of the following screens:

Pi Alarms on page 65

Additional Settings for Pi on page 66

Trends on page 97

About Parameter Information on page 78

Pi Delta on page 130

Pi Alarms

From the *Alarms* screen, change any of the following options:

Options	Description	Alarm Priority	Factory Default Settings	User Configurable Settings
High Limit	High Limit is the upper threshold that triggers an alarm.	Medium	Off	0.04 to 0.09 in steps of 0.01 0.10 to 0.90 in steps of 0.10 1 to 19 in steps of 1, or Off
Low Limit	Low Limit is the lower threshold that triggers an alarm.	Medium	0.3	Off, or 0.03 to 0.09 in steps of 0.01 0.10 to 0.90 in steps of 0.10 1 to 18 in steps of 1
Silence Duration	Sets the amount of time that the alarm is silenced.	NA	2 minutes	30 seconds or 1, 2, or 5 minutes

Additional Settings for Pi

From the *Additional Settings* screen, change the following option:

Options	Description	Factory Default Settings	User Configurable Settings
Averaging Time	The length of time over which the system calculates the average of all data points.	Long	Short or Long

PVi Settings

From the *PVi Settings* screen, access any of the following options:

PVi Alarms on page 66

Additional Settings for PVi on page 67

Trends on page 97

About Parameter Information on page 78

PVi Alarms

From the *Additional Settings* screen, change any of the following options:

Options	Description	Alarm Priority	Factory Default Settings	User Configurable Settings
High Limit	High Limit is the upper threshold that triggers an alarm.	Medium	40	2 to 99, in steps of 1, or Off When set to Off, alarms are disabled.
Low Limit	Low Limit is the lower threshold that triggers an alarm.	Medium	5	Off or 1 to 98 in steps of 1 When set to Off, alarms are disabled.
Silence Duration	Sets the amount of time that the alarm is silenced.	NA	2 minutes	30 seconds or 1, 2, 5, or 10 minutes

Additional Settings for PVi

From the *Additional Settings* screen, change the following option:

Options	Description	Factory Default Settings	User Configurable Settings
Averaging Time	The length of time over which the system calculates the average of all data points.	Long	Short or Long

Respiration Rate (RR) Settings

RRp is currently not available in the U.S.A. and territories relying on FDA market clearance.

Rad-97 can determine Respiration Rate (RR) either by the acoustic signal (RRa) or the plethysmographic waveform (RRp). For more information, see:

RRa Settings on page 68

RRp Settings on page 69

From the *RR Settings* screen, change any of the following options:

RRa Alarms on page 68

RRp Alarms on page 70

Additional Settings for RRa on page 69

Additional Settings for RRp on page 71

Trends on page 97

About Parameter Information on page 78

RRa Settings

RRa is active when the following conditions are all met:

- RRa is installed on the Rad-97.
- A dual rainbow cable is connected.
- An acoustic sensor is connected.

Note: See the Directions for Use provided with the acoustic sensor.

When using an acoustic sensor, Respiration Rate (RR) is determined by the acoustic (RRa) signal. See *rainbow Acoustic Monitoring™ (RAM™)* on page 31. When the respiratory rate is determined by the acoustic signal, the *Main Screen* labels respiratory rate as *RRa*, as shown below.



From the *RR Settings* screen, access any of the following screens:

RRa Alarms on page 68

Additional Settings for RRa on page 69

About Parameter Information on page 78

RRa Alarms

From the *Alarms* screen, change any of the following options:

Options	Description	Alarm Priority	Factory Default Settings	User Configurable Settings
High Limit	High Limit is the upper threshold that triggers an alarm.	High	30 breaths per minute	6 to 69 breaths per minute in steps of 1 breath per minute, or Off
Low Limit	Low Limit is the lower threshold that triggers an alarm.	High	6 breaths per minute	Off, or 5 to 68 breaths per minute in steps of 1 breath per minute
Silence Duration	Sets the amount of time that the alarm is silenced.	NA	2 minutes	30 seconds or 1, 2 or 5 minutes

Options	Description	Alarm Priority	Factory Default Settings	User Configurable Settings
Respiratory Pause	The duration of time that triggers an alarm if no breaths are detected.	NA	30 seconds	15, 20, 25, 30, 35, or 40 seconds
Alarm Delay	When a High or Low alarm condition occurs, this feature delays the audible part of an alarm.	NA	30 seconds	0, 10, 15, 30, or 60 seconds

Additional Settings for RRA

From the *Additional Settings* screen, change any of the following options:

Options	Description	Factory Default Settings	User Configurable Settings
Averaging Time	The length of time over which the system calculates the average of all data points.	Slow	Trending, No Averaging, Fast, Medium, or Slow
Freshness	The duration of time that, during interference, the system displays the last valid reading.	5 minutes	0, 1, 5, 10, or 15 minutes

RRp Settings

RRp is currently not available in the U.S.A. and territories relying on FDA market clearance.

When using a pulse oximetry or pulse CO-Oximetry sensor with Rad-97, respiration rate can be determined by the plethysmographic waveform (RRp). This method measures a patient's respiratory rate based on plethysmographic amplitude changes corresponding to the respiratory cycle. When using a pulse oximetry or pulse CO-Oximetry sensor, RRp alarms and RRp settings are active and the *Main Screen* labels respiratory rate as *RRp*, as shown below.

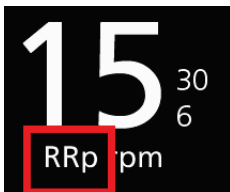

Note that Rad-97 can monitor RRA or RRP but not both simultaneously.

RRp is active when the following conditions have all been met:

- RRP is installed on the Rad-97.
- No dual rainbow cable is connected.
- A pulse oximetry or pulse CO-Oximetry sensor is connected.
- The optical sensor must support RRP.

From the *RR Settings* screen, access any of the following screens:

RRp Alarms on page 70

Additional Settings for RRP on page 71

RRp Alarms

From the *Alarms* screen, change any of the following options:

Options	Description	Alarm Priority	Factory Default Settings	User Configurable Settings
High Limit	High Limit is the upper threshold that triggers an alarm.	High	30 breaths per minute	6 to 69 breaths per minute in steps of 1 breath per minute, or Off
Low Limit	Low Limit is the lower threshold that triggers an alarm.	High	6 breaths per minute	Off, or 5 to 68 breaths per minute in steps of 1 breath per minute
Silence Duration	Sets the amount of time that the alarm is silenced.	NA	2 minutes	30 seconds or 1, 2, or 5 minutes
Alarm Delay	When an alarm condition is met, this feature delays the audible part of an alarm.	NA	30 seconds	0, 10, 15, 30, or 60 seconds

Additional Settings for RRp

From the *Additional Settings* screen, change any of the following options:

Options	Description	Factory Default Settings	User Configurable Settings
Averaging Time	The length of time over which the system calculates the average of all data points.	Slow	No Averaging, Fast, Medium, Slow, Trending
Freshness	The duration of time that, during interference, the system displays the last valid reading.	5 minutes	0, 1, 5, 10, or 15 minutes

SpHb Settings

From the *SpHb Settings* screen, access any of the following screens:

SpHb Alarms on page 72

Additional Settings for SpHb on page 73

In Vivo for SpHb on page 73

Trends on page 97

About Parameter Information on page 78

SpHb Alarms

From the *Alarms* screen, change any of the following options:

Options	Description	Alarm Priority	Factory Default Settings	User Configurable Settings
High Limit	High Limit is the upper threshold that triggers an alarm.	High	17.0 g/dL (11.0 mmol/L) (170 g/L)	2.0 g/dL to 24.5 g/dL in steps of 0.1 g/dL, or Off (2.0 mmol/L to 15.0 mmol/L in steps of 0.1 mmol/L, or Off) (20 g/L to 245 g/L in steps of 1 g/L, or Off) When SpHb Precision is set to 1.0, values are rounded down. When set to Off, alarm is disabled.
Low Limit	Low Limit is the lower threshold that triggers an alarm.	High	7.0 g/dL (4.0 mmol/L) (70 g/L)	Off, or 1.0 g/dL to 23.5 g/dL in steps of 0.1 g/dL (Off, or 1.0 mmol/L to 14.5 mmol/L, in steps of 0.1 mmol/L) (Off, or 10 g/L to 235 g/L in steps of 1 g/L) When SpHb Precision is set to 1.0, values are rounded down. When set to Off, alarm is disabled.
Silence Duration	Sets the amount of time that the alarm is silenced.	NA	2 minutes	30 seconds, 1, 2 or 5 minutes

Additional Settings for SpHb

From the *Additional Settings* screen, change any of the following options:

Options	Description	Factory Default Settings	User Configurable Settings
Averaging Time	The length of time over which the system calculates the average of all data points.	Medium	Short, Medium, or Long
Calibration	Provides an arterial or venous value that displays on the main screen.	Arterial	Arterial or Venous
Precision (units of g/dL and mmol/L)	Allows the user to set the precision of the displayed SpHb value. Note: When unit is g/L, Precision is always 1 (whole numbers)	0.1	0.1, 0.5, or 1.0
Unit of Measure*	Displays total hemoglobin (SpHb) as g/dL (grams per deciliter), g/L (grams per liter), or mmol/L (millimoles per liter). Unit of Measure cannot be changed during active monitoring.	g/dL	g/dL, g/L, or mmol/L

*Changing Unit of Measure will delete all prior trend data for all parameters.

In Vivo for SpHb

In Vivo is currently not available in the U.S.A. and territories relying on FDA market clearance.

From the *In Vivo* screen, change any of the following options:

Options	Description	Factory Default Settings	User Configurable Settings
Enabled	See <i>In Vivo Adjustment Overview</i> on page 61.	Off	On or Off
Offset Amount	See <i>In Vivo Adjustment Overview</i> on page 61.	0.0 when turned on	-3.0 g/dL to +3.0 g/dL in steps of ± 0.1 g/dL

SpOC Settings

From the *SpOC Settings* screen, access the following screens:

SpOC Alarms on page 74

Trends on page 97

About Parameter Information on page 78

SpOC Alarms

From the *SpOC Alarms* screen, access the following screens:

Options	Description	Alarm Priority	Factory Default Settings	User Configurable Settings
High Limit	High Limit is the upper threshold that triggers an alarm.	Medium	25	2 ml/dl to 34 ml/dl in steps of 1 ml/dl, or Off
Low Limit	Low Limit is the lower threshold that triggers an alarm.	High	10	Off, or 1 ml/dl to 33 ml/dl in steps of 1 ml/dl
Silence Duration	Sets the amount of time that the alarm is silenced.	NA	2 minutes	30 seconds or 1, 2, or 5 minutes

SpMet Settings

From the *SpMet Settings* screen, access the following screens:

SpMet Alarms on page 75

In Vivo for SpMet on page 75

Trends on page 97

About Parameter Information on page 78

SpMet Alarms

From the *Alarms* screen, change any of the following options:

Options	Description	Alarm Priority	Factory Default Settings	User Configurable Settings
High Limit	High Alarm Limit is the upper threshold that triggers an alarm.	High	3.0	1.0% to 2.0% in steps of 0.1% 2.5% to 99.5% in steps of 0.5%, or Off
Low Limit	Low Alarm Limit is the lower threshold that triggers an alarm.	Medium	Off	Off, or 0.1% to 2.0% in steps of 0.1% 2.5% to 99% in steps of 0.5%
Silence Duration	Sets the amount of time that the alarm is silenced.	NA	2 minutes	30 seconds, or 1, 2, or 5 minutes

In Vivo for SpMet

In Vivo is currently not available in the U.S.A. and territories relying on FDA market clearance.

From the *In Vivo* screen, access the following screens:

Options	Description	Factory Default Settings	User Configurable Settings
Enabled	See <i>In Vivo Adjustment Overview</i> on page 61	Off	On or Off
Offset Amount	See <i>In Vivo Adjustment Overview</i> on page 61.	0.0 when turned on	-3.0% to +3.0% in steps of 0.1%

SpCO Settings

From the *SpCO Settings* screen, access the following screens:

SpCO Alarms on page 76

In Vivo for SpCO on page 76

Trends on page 97

About Parameter Information on page 78

SpCO Alarms

From the *SpCO Settings* screen, access the following screens:

Options	Description	Alarm Priority	Factory Default Settings	User Configurable Settings
High Limit	High Limit is the upper threshold that triggers an alarm.	High	10	2% to 98%, in steps of 1%, or Off When set to Off, alarm is disabled
Low Limit	Low Limit is the lower threshold that triggers an alarm.	Medium	Off	Off or 1% to 97%, in steps of 1% When set to Off, alarm is disabled
Silence Duration	Sets the amount of time that the alarm is silenced.	NA	2 minutes	30 seconds, 1, 2, or 5 minutes

In Vivo for SpCO

In Vivo is currently not available in the U.S.A. and territories relying on FDA market clearance.

From the *In Vivo* screen, access the following screens:

Options	Description	Factory Default Settings	User Configurable Settings
Enabled	See <i>In Vivo Adjustment Overview</i> on page 61.	Off	On or Off

Options	Description	Factory Default Settings	User Configurable Settings
Offset Amount	See <i>In Vivo Adjustment Overview</i> on page 61.	0.0 when turned on	-9.0% to +9.0% in steps of 0.1%

ORi Settings

ORi is currently not available in the U.S.A. and territories relying on FDA market clearance.

From the *ORi Settings* screen, access the following screens:

ORi Alarms on page 77

Trends on page 97

About Parameter Information on page 78.

ORi Alarms

From the *ORi Alarms* screen, access the following screens:

Options	Description	Alarm Priority	Factory Default Settings	User Configurable Settings
Low Limit	Low Limit is the lower threshold that triggers an alarm.	Medium	Off	Off, or 0.01 to 0.98 in steps of 0.01
Trending Down Alarm	Trending Down Alarm is displayed when a rapid decrease in ORi is measured.	N/A	Off	On or Off
Silence Duration	Sets the amount of time that the alarm is silenced.	N/A	2 minutes	30 seconds or 1, 2, or 5 minutes

About Parameter Information

Additional information about each parameter is available.

To access additional information about parameters:

1. From the *Parameter Settings* screen, touch the **About** icon. The following is an example for SpO₂.



2. An *About* screen appears for the selected parameter and displays information about the parameter.

Additional Settings



Use the *Additional Settings* screen to configure the following:

Option	Description	Factory Default Settings	User Configurable Settings
Sensitivity Mode	Change Sensitivity Mode. See Sensitivity Modes Overview on page 52.	APOD	MAX, APOD, NORM
Waveform Mode	Change the Waveform View. See Waveform Mode on page 79.	Pleth + Sig IQ + Acoustic	Acoustic, Pleth + Sig IQ, Pleth + Sig IQ + Acoustic, PVi Pleth + Sig IQ, or PVi Pleth + Sig IQ + Acoustic
SmartTone	Enable or disable the SmartTone. See Sounds on page 85.	Off	On, Off

Option	Description	Factory Default Settings	User Configurable Settings
SpO ₂ low % limit	Set the SpO ₂ low limit alarm. See <i>SpO₂ Settings</i> on page 62.	Off	Off, 1% to 98%

Waveform Mode

The following section contains examples of some of the waveforms viewable on the *Main Screen*.

Signal IQ Indicators

Signal IQ (SIQ) indicators are displayed as vertical bars for each individual pulsation. The height of the bar provides an assessment of the confidence in the SpO₂ measurement displayed.

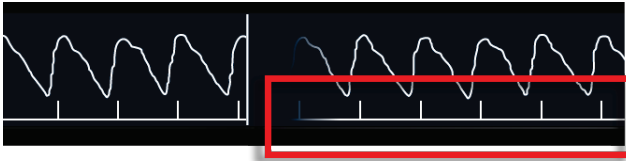

Acoustic Waveform View

The RRa waveform is located above the parameter values. Acoustic Respiratory Rate (RRa) must be available for this feature to be shown. This view contains RRa waveform only.



Pleth + Sig IQ + Acoustic View

The waveform is located above the parameter values. This view contains the Pleth waveform, signal quality indicators, and acoustic waveform (if RRA is available).

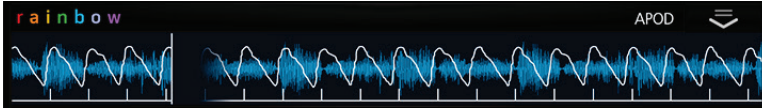

Noninvasive Blood Pressure (NIBP) Settings



Note: This feature is optional on Rad-97 devices.

The *NIBP* menu allows the user to view and customize settings for the NIBP module by changing any of the following options:



Parameter Settings

See *Parameter Settings for Noninvasive Blood Pressure (NIBP)* on page 81.



Intervals

See *Intervals for NIBP* on page 84.



Additional Settings

See *Additional Settings for NIBP* on page 84.



Calibration

See *Calibration for NIBP* on page 85.

Parameter Settings for Noninvasive Blood Pressure (NIBP)



From the *NIBP* screen, touch *Parameter Settings*, and then change individual parameter settings/alarms by selecting one of the following parameters:



Systolic/Diastolic

See *SYS/DIA Settings* on page 81.



Mean Arterial Pressure

See *MAP Settings* on page 82.



Pulse Rate

See *Pulse Rate (PR)* on page 83.

SYS/DIA Settings

From the *Systolic/Diastolic Settings* screen, access the following screens:

SYS/DIA Alarms on page 81

Trends for NIBP on page 82

About Parameter Information on page 78

SYS/DIA Alarms

From the *Systolic/Diastolic Settings* screen, touch *Alarms*, and then change any of the following options:

Options	Description	Alarm Priority	Factory Default Settings	User Configurable Settings
Systolic High Limit	High Limit is the upper threshold that triggers an alarm.	Medium	220	42-259 in steps of 1, or Off When set to Off, alarm is disabled

Options	Description	Alarm Priority	Factory Default Settings	User Configurable Settings
Systolic Low Limit	Low Limit is the lower threshold that triggers an alarm.	Medium	75	Off, or 41-258 in steps of 1 When set to Off, alarm is disabled
Diastolic High Limit	The High Limit is upper threshold that triggers an alarm.	Medium	110	22-199 in steps of 1, or Off When set to Off, alarm is disabled
Diastolic Low Limit	Low Limit is the lower threshold that triggers an alarm.	Medium	35	Off, or 21-198 in steps of 1 When set to Off, alarm is disabled

Trends for NIBP

From the *Systolic/Diastolic Settings* screen, touch *Trends*, and then change any of the following options:

Options	Description	Factory Default Settings	Configurable Options
Y-Axis Max	The NIBP Trend Max, indicating the highest value that will be shown.	260	21-260 in steps of 1
Y-Axis Min	The NIBP Trend Min, indicating the lowest value that will be shown.	20	20-259 in steps of 1

MAP Settings

From the *Mean Arterial Pressure Settings* screen, access the following screens:

MAP Alarms on page 83

About Parameter Information on page 78

MAP Alarms

From the *Mean Arterial Pressure* screen, touch *Alarms*, and then change any of the following options:

Options	Description	Alarm Priority	Factory Default Settings	User Configurable Settings
High Limit	High Limit is the upper threshold that triggers an alarm.	Medium	120	28-219 in steps of 1, or Off When set to Off, alarm is disabled
Low Limit	Low Limit is the lower threshold that triggers an alarm.	Medium	50	Off, or 27-218 in steps of 1 When set to Off, alarm is disabled

Pulse Rate (PR)

From the *Pulse Rate Settings* screen, access the following screens:

Pulse Rate Alarms on page 83

About Parameter Information on page 78

Pulse Rate Alarms

From the *Pulse Rate Settings* screen, touch *Alarms*, and then change any of the following options:

Options	Description	Alarm Priority	Factory Default Settings	User Configurable Settings
High Limit	High Limit is the upper threshold that triggers an alarm.	Medium	120	40-210 in steps of 5, or Off When set to Off, alarm is disabled
Low Limit	Low Limit is the lower threshold that triggers an alarm.	Medium	50	Off, or 35-215 in steps of 5 When set to Off, alarm is disabled

Intervals for NIBP



From the *NIBP* screen, touch *Intervals*, and then change any of the following options:

Options	Description	Factory Default Settings	User Configurable Settings
Set Mode	The mode of measurement for NIBP.	Automatic	Automatic or Stat
Interval	Note: Option available when Automatic mode is selected. Automatic interval measurement mode will take blood pressure measurements once every desired interval.	15 minutes	2, 3, 4, 5, 10, 15, 30, 60, or 90 minutes
Stat Duration	Note: Option available when Stat mode is selected. Stat interval measurement mode will take blood pressure measurements continually for the desired duration.	10 minutes	5 or 10 minutes
Start Auto/Start Stat	Starts NIBP measurement	NA	NA

Additional Settings for NIBP



Use the *Additional Settings* screen to configure the following option:

Options	Description	Factory Default Settings	User Configurable Settings
Measurement Timeout	Set the measurement timeout value.	15 minutes	5, 10, 15, 30, 60, or 90 minutes

Calibration for NIBP



The *Calibration* option on the *NIBP* menu allows a qualified service professional to access calibration settings and tools for the NIBP module. For more information, see **Chapter 12: Service and Maintenance** on page 167.

Note: This section is provided as a reference and intended for qualified service professionals only.

Sounds



Use the *Sounds* screen to control the volume of sounds and duration of audio pause on Rad-97. Users can also access the *Sounds* screen by pressing the *Sounds* icon on the Status Bar. See **About the Status Bar** on page 49.

Option	Description	Factory Default Settings	User Configurable Settings
Alarm Volume	Sets the alarm volume level.	4 (Highest volume)	1 to 4 - Slide towards the left to decrease volume and to silence.
Pulse Tone Volume	Sets the pulse tone volume level.	3	0 to 4 - Slide towards the left to decrease volume and to silence.
Audio Pause Duration	Sets the length of time that the audible alarm remains silenced, when Audio Pause is enabled. See Audio Pause on page 126.	2 minutes	1, 2, or 3 minutes, Permanent **, or Permanent with Reminder ***.
SmartTone	Allows the audible pulse to continue to beep when the pleth graph shows signs of motion.	Off	On or Off

* Requires user to have All Mute Enabled turned on in the *Access Control* menu. See **Access Control** on page 94.

** If *Permanent* is selected, there will be no audible alarms, but visual alarms will still display.

*** If *Permanent with Reminder* is selected, a tone will sound every three (3) minutes as a reminder that *Permanent* is active.

Device Settings



The *Device Settings* menu allows the user to view and customize settings for Rad-97.

Note: When in *Home* mode, items below marked with an * are displayed in the *Main Menu*; no other device settings are available. See **Home** on page 89.

The *Device Settings* options are:



Localization

See **Localization** on page 87.



Device Mode

See **Device Mode** on page 88.



Screen Orientation*

See **Screen Orientation** on page 91.



Ethernet

See **Ethernet** on page 91.



Wi-Fi

See **Wi-Fi** on page 92.



Bluetooth

See **Bluetooth** on page 92.



Rad-97 Battery*

See **Rad-97 Battery** on page 93.



Brightness*

See **Brightness** on page 94.



Access Control

See **Access Control** on page 94.



Device Output

See **Device Output** on page 96.

Localization



Use the *Localization* screen to view the current date and time and configure settings related to local time, language and geography. The user can also access the *Localization* screen by pressing the current time on the *Status Bar*. See **About the Status Bar** on page 49.

Option	Description	Factory Default Settings	User Configurable Settings
Language	Select the language display for Rad-97.	English	Choose from available languages.
Date Format	Set the display format for current date.	mm/dd/yy	mm/dd/yy or dd/mm/yy
Time Format	Set the display format for current time.	12 hour	12 or 24 hour
Line Frequency	Set to match regional power line frequency.	60 Hz	50 Hz or 60 Hz
Date	Set the current date.	N/A	month, date, and year
Time	Set the current time.	N/A	hour and minutes AM or PM

Device Mode



The *Device Mode* screen allows the user to select the device operating mode. Continuous Monitoring is the default device mode. When the Rad-97 is turned off, the device mode is stored. Rad-97 will start in the same mode when turned on again.

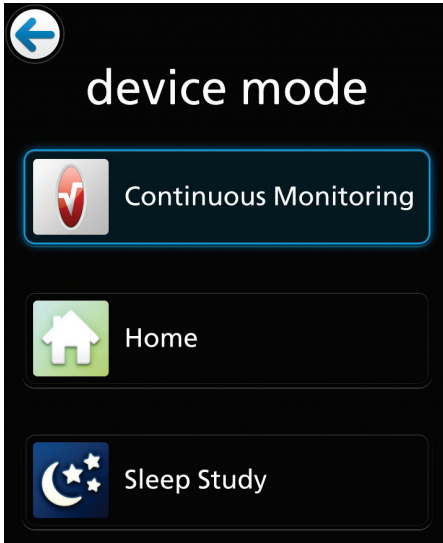

Note: Home mode is an optional feature.

Access to the *Device Mode* screen is password protected.

1. When the screen displays, press the 123 key.
2. Enter the following: **6 2 7 4**
To undo an entry, press the *Backspace* key.
3. Press the *Enter* key to access the *Device Mode* screen.
4. Select the desired option and select *OK* to set the device mode.

Continuous Monitoring



Continuous Monitoring mode is the standard mode of operation of the Rad-97 and includes all functionality outlined in this Operator's Manual.

Home



When optional Home mode is available, Rad-97 operates using the Continuous Monitoring settings in effect at the time Home mode is enabled (Profiles, Alarms, Trends, etc.). Rad-97 operation changes as follows when in Home mode:

- Alarm tone volume is set to the highest level and cannot be changed.
- Pulse tone volume can be changed; however, all other sound settings are disabled.
- The Alarm Silence button is not included on the *Main Screen*. See **About Alarms** on page 124.
- Profile settings are not available (device operates in the profile set during Continuous Monitoring mode).
- When parameters in the *Main Menu* are selected, only parameter information is displayed. Settings are not displayed or available. See **About Parameter Information** on page 78.
- *Profiles, Device Settings, and Trend Settings* are not displayed in the *Main Menu*.

Change Settings/Exit Home Mode

To change settings or switch to a different device mode, select the *Rad-97* menu from the *Main Menu*.

1. When the screen displays, press the **123** key.
2. Enter the following: **6 2 7 4**
To undo an entry, press the *Backspace* key.
3. Press the *Enter* key. The *Main Menu* screen will display.
 - From the *Main Menu*, make changes to Rad-97 settings as necessary and select the back button to return to *Home* mode operation.
 - From the *Main Menu*, select *Device Settings > Device Mode* to change operating modes.

Sleep Study



When in Sleep Study mode, Rad-97 operates using the Continuous Monitoring settings in effect at the time Sleep Study mode is enabled (Profiles, Alarms, etc.). Rad-97 operation changes as follows when in Sleep Study mode:

- Audible alarms are disabled.
- Visual alarms display. If the display is off when an alarm triggers, the display wakes and displays the visual alarm until the alarm event is resolved.
- Sounds are disabled and cannot be changed.
- Profile settings are not available (device operates in the profile set during Continuous Monitoring mode).
- Home button illumination turns off.
- SpO₂ averaging time defaults to 2-4 seconds and cannot be changed. See ***Additional Settings for SpO₂*** on page 63.
- The display times out and turns off after approximately 10 seconds. Touch the display to wake.

Change Settings or Device Mode

To make changes to unavailable settings listed above or switch to a different device mode, select *Device Settings* > *Device Mode*.

1. When the screen displays, press the **123** key.
2. Enter the following: **6 2 7 4**
To undo an entry, press the *Backspace* key.
3. Select *Continuous Monitoring* to change operating modes, allowing changes to previously unavailable settings.
4. After making changes, go back to *Device Mode* and select *Sleep Study* to resume.

Screen Orientation



Use *Screen Orientation* to set screen preferences.

From the *Screen Orientation* screen, change any of the following options:

Options	Description	Factory Default Settings	User Configurable Settings
Auto Orientation	Allows the device to automatically adjust screen content depending on device orientation.	On	Off or On
Orientation	When Auto Orientation is Off, allows the user to manually set screen orientation.	Portrait (with device in vertical position) Landscape (with device in horizontal position)	Portrait, Inverted Portrait, Landscape, or Inverted Landscape

Ethernet



Use the *Ethernet* screen to enable or disable Ethernet connectivity. When Ethernet connectivity is enabled, the Ethernet icon will appear in the Status Bar. The user can also access the Ethernet screen by pressing the Ethernet icon on the Status Bar. See **About the Status Bar** on page 49.

Option	Description	Factory Default Settings	User Configurable Settings
Ethernet	Enables or disables Ethernet connectivity.	On	On or Off
Additional fields in the Ethernet screen display read-only settings about the Ethernet connectivity that cannot be configured by the user.			

Wi-Fi



The Wi-Fi radio allows for networked communication of data and alarm signals between Rad-97 and a secondary patient monitoring station, Masimo Patient SafetyNet, over an IEEE 802.11 a/b/g wireless network.

Rad-97 uses only configured MAC addresses to establish wireless communications to prevent unauthorized connections to other wireless devices. As risk mitigation, in the event of the loss of wireless communication, Rad-97 alarm capabilities are designed to be independent of Wi-Fi communication in order to ensure alarms are received.

Use the *Wi-Fi* screen to enable or disable Wi-Fi connectivity. When Rad-97 is connected to a Wi-Fi network, the Wi-Fi icon on the Status Bar indicates the strength of the connection. The user can also access the Wi-Fi screen by pressing the Wi-Fi icon on the Status Bar. See ***About the Status Bar*** on page 49.

Option	Description	Factory Default Settings	User Configurable Settings
Wi-Fi	Enables or disables Wi-Fi connectivity.	Off	On or Off
Additional fields in the <i>Wi-Fi</i> screen display read-only settings about the Wi-Fi connection that cannot be configured by the user.			

Your Masimo sales representative can provide necessary information regarding an initial Wi-Fi connection.

Bluetooth



Use the *Bluetooth* screen to enable or disable Bluetooth connectivity. When Bluetooth connectivity is enabled, the Bluetooth icon will appear in the Status Bar. The user can also access the Bluetooth screen by pressing the *Bluetooth* icon on the Status Bar. See ***About the Status Bar*** on page 49.

Option	Description	Factory Default Settings	User Configurable Settings
Bluetooth	Enables or disables Bluetooth connectivity.	Off	On or Off

Option	Description	Factory Default Settings	User Configurable Settings
Presence Monitoring	Used in conjunction with MyView on Masimo Patient SafetyNet (see the Masimo Patient SafetyNet Operator's Manual).	Off	On or Off
Additional fields in the <i>Bluetooth</i> screen display read-only settings about the Bluetooth connection that cannot be configured by the user.			

Your Masimo sales representative can provide necessary information regarding an initial Bluetooth connection.

Note: Presence Monitoring must be disabled in order for Rad-97 to function. For more information on how to configure the Masimo MyView Presence Tag, see the Masimo Patient SafetyNet Operator's Manual.

Rad-97 Battery



Use the Battery screen to view the specific percentage of charge remaining in Rad-97's battery. The user can also access the Battery screen by pressing the Battery icon on the Status Bar. See **About the Status Bar** on page 49.

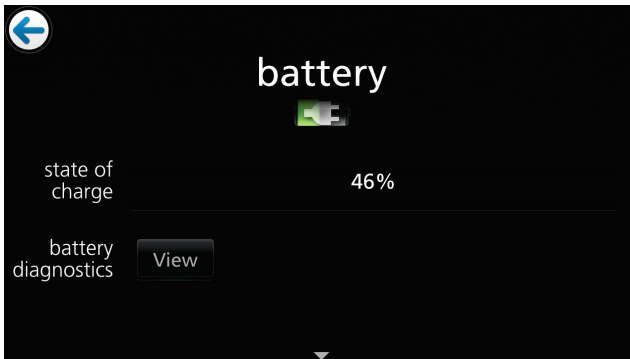

Option	Description
State of Charge	Provides a read-only display of battery level remaining.
Battery Diagnostics	Allows trained personnel to access battery diagnostic information.

Brightness



Use the *Brightness* screen to adjust the brightness of Rad-97's display.

Option	Description	Factory Default Settings	User Configurable Settings
Auto Brightness	Allows automatic adjustment of display brightness based on the ambient light level.	Off	On or Off
Brightness	Adjust the brightness level of the display manually.	4	1 (dimkest), 2, 3, 4 (brightest)

Access Control



The *Access Control* screen contains configurable options and settings that require a password to view or change.

To enter Access Control

1. Press the **123** key.



2. When the screen displays, enter the following: **6 2 7 4**
Asterisks (****) will be displayed.

To undo an entry, press *Backspace*.

3. Press *Enter* to access the password-protected screen.

Note: The password will have to be entered every time this screen is accessed.

Option	Description	Factory Default Settings	User Configurable Settings
Power on Profile	Sets the profile used when the device is powered on. See Chapter 5: Profiles on page 103.	Previous Profile	Previous Profile, Adult, Pediatric, Neonatal, or User defined profile (up to 8)
All Mute Enabled	Enables parameter Alarm Silence menu option. See Sounds on page 85.	Off	On or Off
Lock Alarm Volume	Sets the lowest alarm volume level.	Off	3, 4, or Off
Screen Lock	Allows the user to lock the touchscreen to prevent accidental changes.	Off	On or Off
USB Port Baudrate	Sets the USB port communication speed.	921600	9600, 19200, 38400, 57600, 115200, 230400, or 921600
Data Collection Enabled	Enables or disables physical data collection mode.	Off	On or Off
Save as Adult*	Saves current profile parameter as the Adult Profile.	N/A	Press Save to update the profile.
Save as Pediatric*	Saves current profile parameter as the Pediatric Profile.	N/A	Press Save to update the profile.
Save as Neo*	Saves current profile parameter as the Neonatal Profile.	N/A	Press Save to update the profile.
Factory Defaults	Options are restored to factory values.	N/A	Press Restore .

* See **Replacing Factory Default Settings for Adult, Pediatric and Neonatal Profiles** on page 107.

Device Output



The *Device Output* screen allows the user to configure additional data output options. A Nurse Call can be triggered based on alarm, low Signal IQ events, or both. In addition, Nurse Call Polarity can be inverted to accommodate local Nurse Call station requirements.

The *Device Output* screen can also be accessed by selecting the Device Output icon on the Status Bar. See **About the Status Bar** on page 49.

Option	Description	Factory Default Setting	Configurable Settings
Nurse Call Trigger	Controls the source of monitoring which sets off the trigger.	Alarms	Alarms, Alarms+SIQ, or Low SIQ
Nurse Call Polarity	Controls the mechanism of action for triggering to occur. Should be changed to accommodate institutional Nurse Call settings.	Normal	Normal or Inverted
USB Port*	Controls the communication protocol used to transmit parameter data to a 3rd party device or an EMR system.	IAP	None, IAP, ASCII 1, or IntelliBridge
IntelliBridge Module	Identifies the type of IntelliBridge Module connected to the USB Port. Note: USB Port selection must be IntelliBridge for option to be available.	EC-10/B	EC-10/B or A

* When IAP, ASCII 1, or IntelliBridge is selected, the Device Output icon displays in the Status Bar. If **None** is selected, no Device Output icons display in the Status Bar. See **About the Status Bar** on page 49.

Note: The Nurse Call feature is disabled when Audio Pause is enabled and Nurse Call Trigger is set to *Alarms*. For more information about Audio Pause, see **Audio Pause** on page 126.

About



For information about individual parameters, see **About Parameter Information** on page 78.

Use the *About* screen to view the serial number as well as Rad-97 software and hardware version information. These details may be helpful during troubleshooting.

Option *	Description
Serial Number	Displays the serial number for the device.
MCU	Displays the version number of the device board software.
Processor	Displays the version number of the system level software.
MX Board	Displays the version number of the technology level software.

* These fields are read-only and cannot be configured by the user.

Trends



Trend settings allow the user to configure the Y-axis maximum and Y-axis minimum for each parameter. The maximum and minimum possible values differ depending on the selected parameter. See **Customizing Trend View** on page 54 for additional information.

Trend Settings

Use the *Trend Settings* screen to configure Trend Views on the *Main Screen* and trend data storage on Rad-97.

Option	Description	Factory Default Settings	User Configurable Settings
Default Duration	Sets the time duration displayed in trend lines.	2 hours	15, 30, or 45 minutes 1, 2, 4, 8, 12, or 24 hours
Clear Trends	Deletes all stored trend data.	N/A	Press Clear to delete all stored trend data.

Option	Description	Factory Default Settings	User Configurable Settings
SpO ₂	Y-axis Min	50	0 to 95 in steps of 5
	Y-axis Max	100	5 to 100 in steps of 5
PR	Y-axis Min	25	25 to 235 in steps of 5
	Y-axis Max	200	30 to 240 in steps of 5
SpHb g/dL	Y-axis Min	5.0 g/dL	0.0 to 24.9 g/dL in increments of 0.1
	Y-axis Max	20.0 g/dL	0.1 to 25.0 g/dL in increments of 0.1
SpHb mmol/L	Y-axis Min	3.1 mmol/L	0.0 to 15.4 mmol/L in increments of 0.1
	Y-axis Max	12.4 mmol/L	0.1 to 15.5 mmol/L in increments of 0.1
SpHb g/L	Y-axis Min	50 g/L	0 to 249 g/L in steps of 1
	Y-axis Max	200 g/L	1 to 250 g/L in steps of 1
RRa	Y-axis Min	0	0 to 69 in steps of 1
	Y-axis Max	35	1 to 70 in steps of 1
RRp*	Y-axis Min	0	0 to 69 in steps of 1
	Y-axis Max	35	1 to 70 in steps of 1
SpCO	Y-axis Min	0	0 to 99 in steps of 1
	Y-axis Max	40	1 to 100 in steps of 1
SpMet	Y-axis Min	0.0	0.0 to 99.5 in increments of 0.5
	Y-axis Max	15.0	1.0 to 100.0 in increments of 0.5

Option	Description	Factory Default Settings	User Configurable Settings
Pi	Y-axis Min	0.0	0.0 to 19.0 in increments of 1.0
	Y-axis Max	20.0	1.0 to 20.0 in increments of 1.0
PVi	Y-axis Min	0	0 to 99 in steps of 1
	Y-axis Max	30	1 to 100 in steps of 1
SpOC	Y-axis Min	0	0 to 34 in steps of 1
	Y-axis Max	20	1 to 35 in steps of 1
ORi*	Y-axis Min	0.00	0.00 to 0.99 in increments of 1.0
	Y-axis Max	1.00	0.01 to 1.00 in increments of 1.0

*Parameter currently not available in the U.S.A. and territories relying on FDA market clearance.

Note: When the device is in optional Home mode (if available), Trend settings are not available. The device operates using the Trend settings set during Continuous Monitoring mode. See **Home** on page 89.

Rad-97 Screenshot Capture

The user is able to take screenshots of Rad-97 displays and download them as .png files onto a USB drive. To ensure quick downloads, the number of screenshots that can be stored in Rad-97 is limited to 20; once the limit is reached, every new screenshot taken will replace the oldest screenshot taken.

Note: Download the images onto a USB drive to avoid loss of the screenshots.

Note: There must be a folder titled "screen_shot" in the USB drive with a FAT or FAT32 system file to enable the download of the screenshots.

Capturing Screenshots

To take a screenshot, swipe across the Rad-97 screen from right to left using 2 or more fingers simultaneously.

- A confirmation flash will appear on the entire screen and a status message will be displayed briefly at the top of the Rad-97 screen.
- The status message indicates the filename of the screenshot taken.

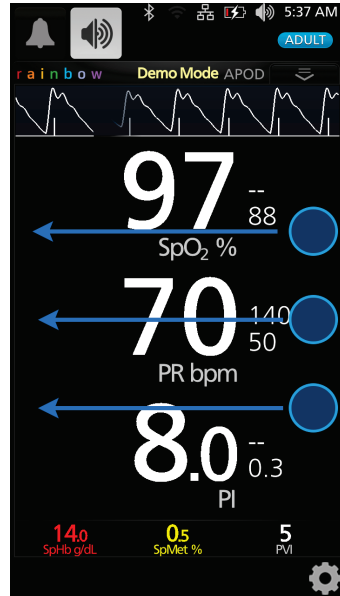

Downloading Screenshots

To download the screenshots:



1. Remove any sensors connected to the patient to stop monitoring, and acknowledge any alarms triggered on Rad-97.
Note: Before connecting the USB drive in the next step, there must be a folder titled "screen_shot" in the USB drive with a FAT or FAT32 system file to enable the download of the screenshots.
2. Plug the USB drive into the USB port located on the back side of Rad-97 (see **Back View** on page 37), and the screenshots will automatically download. A status message will display briefly at the top of the Rad-97 screen to indicate the start of the download.
3. A confirmation status message will display briefly at the top of the Rad-97 screen when the file transfer is complete.
4. Unplug the USB drive from Rad-97.

To import the screenshots from the USB drive onto a computer, plug the USB drive into the computer's USB port, then open the folder titled "screen_shot" (from the USB drive) on the computer to access the .png files.

Patient Admit/Discharge

When configured, this function allows the user to admit and discharge a patient through Patient SafetyNet.

Depending on patient status, different icons display on the *Main Screen*.

Icon	Name	Description
	Admit	Select to admit a patient.
	Discharge	Indicates a patient is currently admitted. Select to discharge admitted patient.

For complete information and the steps to admit and discharge a patient, see **Chapter 7: Admit to and Discharge from Patient SafetyNet** on page 117.

Chapter 5: Profiles

The following chapter contains information about profiles and profile settings.

Profiles Overview

Note: When in Sleep Study mode or optional Home mode (when available), *Profiles* settings are not available. The device operates in the profile set during *Continuous Monitoring* mode. See **Sleep Study** on page 90 and **Home** on page 89.

Rad-97 contains a *Profiles* screen which lets the user customize settings for different patient populations:

- **Adult**
Adult profile is the factory default profile. Displays in the Status bar as *ADULT* and the color of the Profile button turns Blue.
- **Pediatric**
Displays in the Status bar as *PEDIATRIC* and the color of the Profile button turns Green.
- **Neonatal**
Displays in the Status bar as *NEO* and the color of the Profile button turns Pink.

If the Profile setting is changed to *NEO*, Rad-97 will remain in the previously selected Profile setting even after the device is powered off and on again.

Note: If no changes are made to the profile settings, Rad-97 automatically resets to the default *Adult* profile after the device is powered off and on again.

The active profile displays in the Status Bar. In the following example, the *Adult* profile is active.



To restore all Rad-97 settings to factory default settings, see **Access Control** on page 94.

Changing Profiles

Changing Profiles is done through the *Profiles Settings* screen. There are different ways to access the *Profiles Settings* screen.

- Touch the *Profiles* shortcut in the Status Bar, as shown below.



- Select *Profiles* from the Main Menu as shown below.



Once the *Profiles* screen displays you can switch to a different profile or choose a different patient category (Adult, Pediatric, Neonate) for the selected profile.

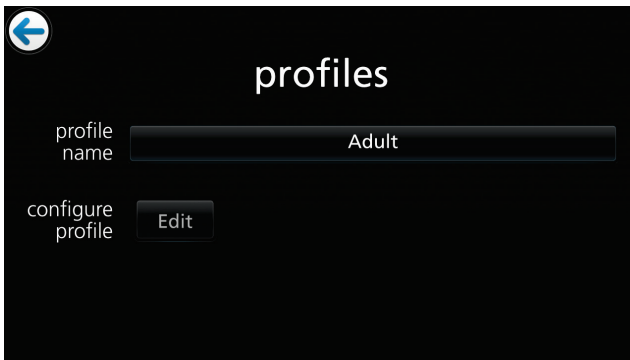

To switch to a different profile:

From the *Profiles* screen, touch the *Profile Name* field.

1. Select the desired profile by scrolling up or down.

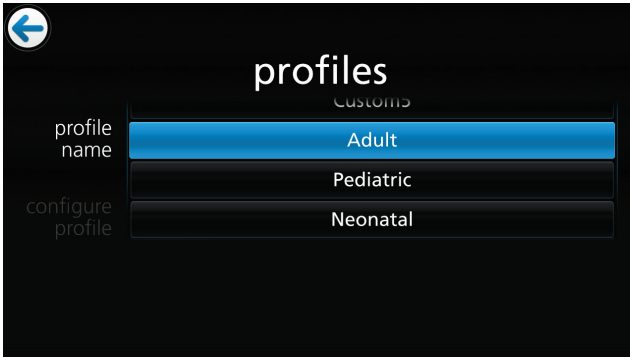

2. When finished, touch **OK**. To confirm selection, check the Status Bar. The Home Button color will change as follows, depending on the profile selected:
 - Adult = Blue
 - Pediatric = Green
 - Neonatal = Purple
 - If the profile is displayed with an asterisk*, Home button illumination is turned Off.

To choose a different category for the selected patient profile:

From the *Profiles* screen, touch the *Configure Profile* Edit button.

1. Select the desired patient category by scrolling up or down.
2. When finished, touch **OK**. To confirm selection, check the Status Bar.
3. If a non-matching category is selected, the profile will be displayed with an asterisk* and the profile name on the status bar will not be highlighted with a color.

Profiles Settings



The Rad-97 can be configured for various patient types through the Profiles option located under the main menu options. See **Accessing Main Menu Options** on page 57.

Use the *Profiles Settings* screen to select patient type.

Option	Description	Factory Default Setting	Configurable Settings
Profile Name	Identifies the profile currently active on Rad-97.	Adult	Adult, Pediatric, Neonatal, Custom*
Patient Category**	Identifies the patient category type.	Adult	Adult, Pediatric, Neonatal

* In addition to the three (3) standard profiles (Adult, Pediatric, Neonatal), up to eight (8) custom profiles can be created as well.

** Select *Edit* to access the Patient Category options screen.

Replacing Factory Default Settings for Adult, Pediatric and Neonatal Profiles

The default *Adult*, *Pediatric* and *Neonatal* profile settings can be modified to suit user preferences and the modified profiles saved as the default settings. This allows Rad-97 to remember customized settings for adult, pediatric and neonatal patients when the default *Adult*, *Pediatric* and *Neonatal* profiles are selected, even after the device is powered down and restarted. When customized settings for *Adult*, *Pediatric* and *Neonatal* profiles are saved in place of the factory default settings, the *Profile* button still changes to the same Blue, Green or Pink color, respectively. See **Profiles Overview** on page 103.

The user can also load preferred profile settings into the Rad-97 using a separate tool.

To change the factory default settings for *Adult*, *Pediatric* or *Neonatal* profile settings

1. Change Rad-97 settings to the desired configuration.
2. Navigate to the *Access Control* screen. See **Access Control** on page 94.
3. Touch **Save** to save the change to the default profile.

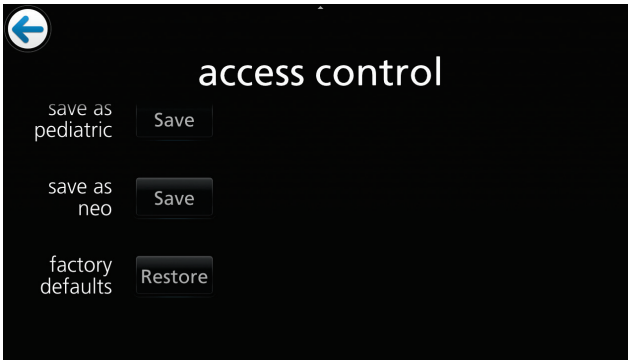

4. Touch **Ok** to confirm the change.
5. Alternatively, the user can restore all *Profile* settings to factory default values by touching **Restore** and then **Ok**.
6. Confirm the changes by powering off and powering on Rad-97; the modified profile settings should remain intact.

Chapter 6: Noninvasive Blood Pressure (NIBP)

Operation - NIBP

Note: This feature is optional on Rad-97 devices.

Rad-97 works by noninvasively monitoring the amplitude of cuff pressure changes during cuff deflation to determine arterial blood pressure. The cuff pressure is first elevated above the patient's systolic blood pressure level. The cuff will then begin to deflate at a certain rate. The initial rise in the amplitude of pressure fluctuations during cuff deflation corresponds closely to the systolic blood pressure. As the cuff is further deflated, the pressure fluctuations increase in amplitude until a peak is reached which is usually referred to as the mean arterial pressure (MAP). As cuff deflation continues, the diastolic pressure can be determined based upon the rapidly diminishing amplitude of the pressure fluctuations.

Patient Category

The below table provides a method for selecting the appropriate Noninvasive Blood Pressure (NIBP) patient category. To change patient category see **Chapter 5: Profiles** on page 103.

Weight	Patient Category	Maximum Pressure
Greater than 75lbs (34kg)	Adult	280 mmHg
Between 15.4-75lbs (7-34kg)	Pediatric	280 mmHg
Less than 15.4lbs (7kg)	Neonatal	140 mmHg

Patient Conditions

When measuring the patient's blood pressure, it is recommended that the patient be in Normal Use position, as described below.

Ensure that the following conditions are met before taking the patient's blood pressure:

- Patient is comfortably seated
- Patient's legs are uncrossed
- Patient's feet are flat on the floor
- Patient's back and arms are supported
- The middle of the cuff is at the level of the right atrium of the heart

CAUTION: Blood pressure measurements can be affected by the patient's position, physiological condition, and environmental factors.

Note: Physiological conditions that can affect blood pressure measurements include, but are not limited to, cardiac arrhythmias, arterial sclerosis, poor perfusion, diabetes, age, pregnancy, pre-eclampsia, renal diseases, trembling, and shivering.

Note: It is recommended that the clinician ask the patient to relax and not speak during measurement.

Note: It is recommended that 5 minutes elapse before the first reading is taken.

Cuff Selection and Placement

Rad-97 uses a quick connect hose with a blood pressure cuff to measure NIBP. Based on the cuff type selected, use the following approved blood pressure cuff chart to choose sizes.

Accessory	Length
NIBP Patient Hose, Male Quick Connect	3 meters (9.8 feet)
NIBP Patient Hose, Female Bayonet	3 meters (9.8 feet)
Cuff Type	Size (color), Range - cm
Reusable Masimo Blood Pressure Cuff	Child (green), 12 - 19 Small Adult (turquoise), 17 - 25 Adult (navy blue), 23 - 33 Large Adult (burgundy), 31 - 40
Disposable Neonatal Blood Pressure Cuff	Neonate #1, 3 - 6 Neonate #2, 4 - 8 Neonate #3, 6 - 11 Neonate #4, 7 - 13 Neonate #5, 8 - 15

To ensure the correct cuff size

Wrap the cuff around the arm.

The index line | I N D E X | should align within the cuff range markings | ← RANGE → |.

If the index line does not fit within the range markings, select a larger or smaller cuff.

To place cuff on the measurement site

Wrap the cuff around the non-dominant arm, making sure that the Artery Marker is aligned over the brachial artery as shown in the image below. If possible, do not wrap the cuff over the patient's clothing. The cuff should fit snugly around the patient's arm for maximum oscillometric signal quality. The lower edge of the cuff should be located 2 cm above the antecubital fossa (interior bend of the elbow).

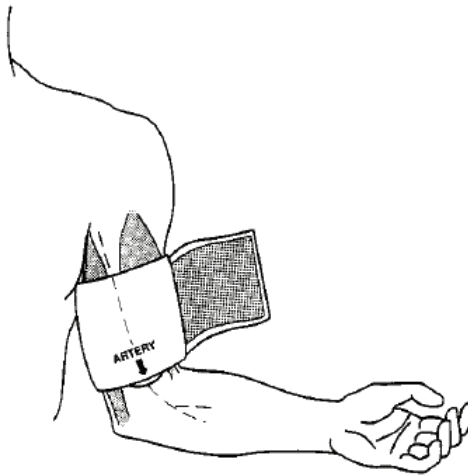

Ensure that the air hose from the monitor to the cuff is not compressed, crimped, or damaged.

Blood Pressure Measurement

Spot Check NIBP Measurement

1. Ensure that the correct patient profile is selected before measurement.

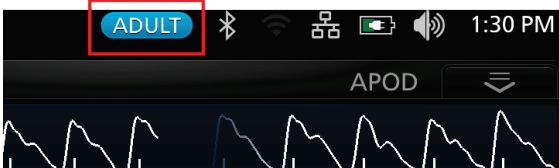

WARNING: Only use Rad-97 in Neonatal mode with a neonatal blood pressure cuff to measure blood pressure on neonates.

Note: The *Patient Category* determines the initial inflation pressure of NIBP. Ensure that the proper patient profile and associated patient category are appropriate for the intended patient.

2. To change the patient profile, touch the *Main Menu* icon , then select *Profiles*



Touch the *Profile Name* and select the desired patient profile.

3. Properly place the blood pressure cuff on patient. See **Cuff Selection and Placement** on page 110.
4. Touch the *Start* button to begin measurement.

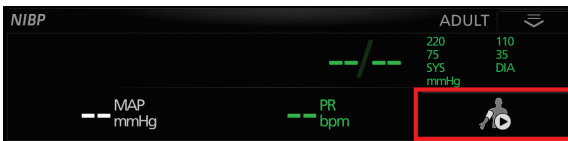

5. Wait for measurement to complete or touch the *Stop* button to stop measurement.

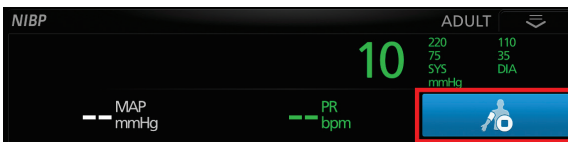

6. Wait for measurement values to appear to ensure that the NIBP measurement is complete.

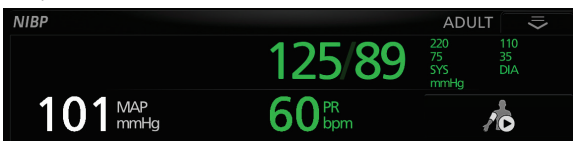

Automatic Interval Measurement



Automatic Interval Measurement mode will take blood pressure measurements once every desired interval.

To measure blood pressure in Automatic Interval Measurement Mode

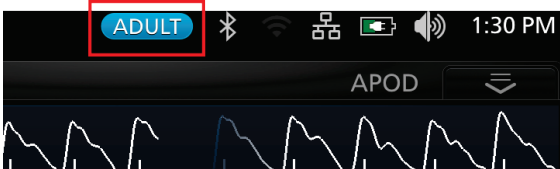
1. Ensure that the correct patient profile is selected before measurement.





WARNING: Only use Rad-97 in Neonatal mode with a neonatal blood pressure cuff to measure blood pressure on neonates.

2. To change the patient profile, touch the *Main Menu* icon , then select *Profiles* .

Touch the *Profile Name* and select the desired patient profile.

3. Properly place the blood pressure cuff on patient. See **Cuff Selection and Placement** on page 110.

4. To enable *Automatic* mode, touch the *Main Menu* icon , then select *NIBP Settings* .

On the *Intervals* screen, change *Set Mode* to *Automatic*, and then select the desired *Interval*. The measurement mode can also be changed using the action menu.

WARNING: Too frequent blood pressure measurements can cause injury to the patient due to blood flow interference.

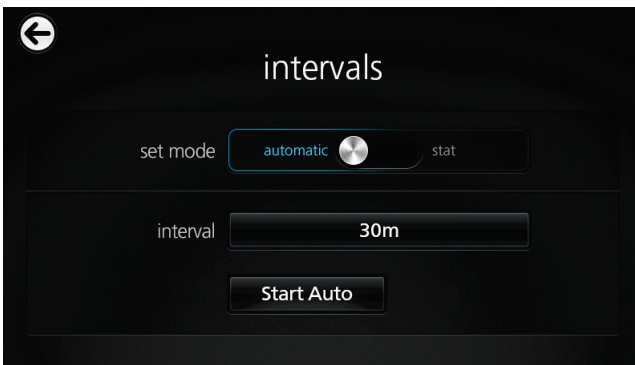

- To begin measurement, touch the *Start Auto* button and then press the arrow in the top-left corner of the touchscreen to return to the *Main Screen*.

Note: An Automatic Interval NIBP measurement can also be started directly from the Action Menu in the NIBP window. See **About the Action Menu** on page 51.
- The device will begin the Automatic Interval Measurement and display the specified interval designated by the clinician (15 minutes in the example below).
- Wait for measurement to complete or touch the *Stop* button to stop the measurement.

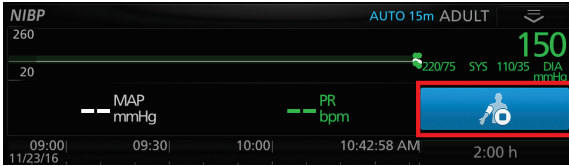

Note: Once finished measuring, values will appear and the next measurement will begin after the specified interval.

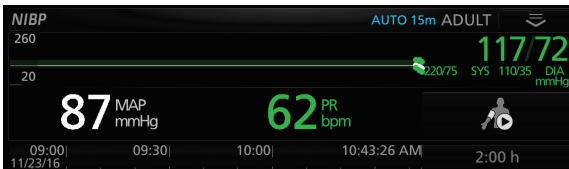

Stat Interval NIBP Measurement



Stat Interval Measurement mode will take blood pressure measurements continuously for the desired duration.

To measure blood pressure in Stat Interval Measurement Mode

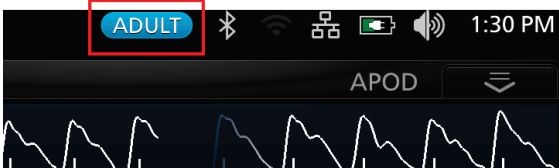
- Ensure that the correct patient profile is selected before measurement.



WARNING: Only use Rad-97 in Neonatal mode with a neonatal blood pressure cuff to measure blood pressure on neonates.

- To change the patient profile, touch the *Main Menu* icon , then select *Profiles* .

Touch the *Profile Name* to select the desired patient profile.

3. Properly place the blood pressure cuff on patient. See **Cuff Selection and Placement** on page 110.
4. To enable Stat mode, touch the **Main Menu** icon , then select **NIBP Settings**



On the **Intervals** screen, change **Set Mode** to **Stat**, and then select the desired **Stat Duration**. The measurement site can also be changed using the action menu.

WARNING: Too frequent blood pressure measurements can cause injury to the patient due to blood flow interference.

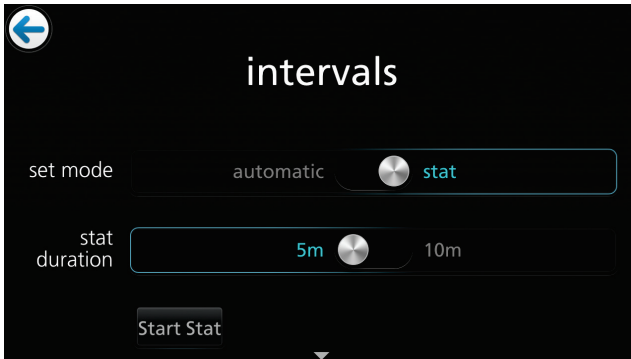

5. To begin measurement, touch the **Start Stat** button and then press the arrow in the top-left corner of the touchscreen to return to the **Main Screen**.
Note: A Stat Interval NIBP measurement can also be started directly from the Action Menu in the NIBP window. See **About the Action Menu** on page 51.
6. Wait for measurement to complete or touch the **Stop** button to stop the measurement.

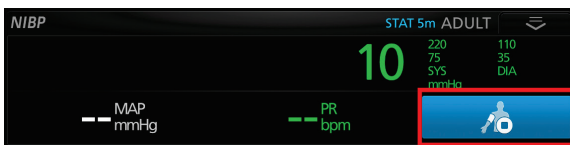

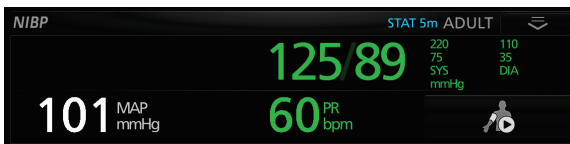

Note: Once measurement is completed and values appear, the next measurement will begin and repeat until duration time has elapsed.



Chapter 7: Admit to and Discharge from Patient SafetyNet

The *Admit/Discharge* icon is located in the bottom left of the screen and allows clinicians to admit or discharge patient's on Masimo Patient SafetyNet directly from Rad-97.

Icon	Description
	Admit - Select to admit a patient.
	Discharge - Indicates a patient is currently admitted. Select to discharge admitted patient.

Note: In order to use this feature, Masimo Patient SafetyNet software V5.0.6.5 or higher is required.

Not Admitted

A **Not Admitted** message will appear on the Rad-97 screen when the sensor is placed onto a patient and a patient has not yet been admitted on Rad-97. Press the *Admit* button on the screen to admit the patient or press *Skip* and the patient data will not be transmitted to Patient Safety Net.

Admitting a Patient

1. Press the *Admit* icon  on the bottom left of the screen to open the *Patient* screen.
2. Select the patient name by pressing the *Search* button (see Fig. 1).
3. Select the patient's name from the list (see Fig. 2) or filter by typing the patient's last name and selecting the patient from the filtered list.

Fig. 1

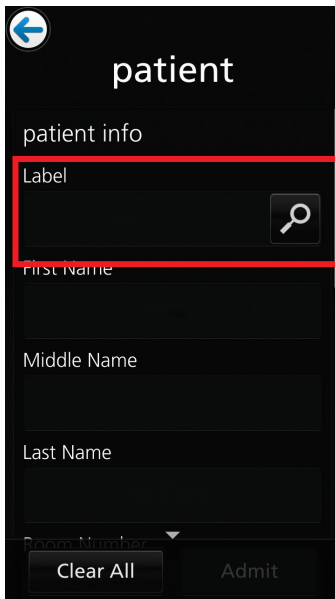
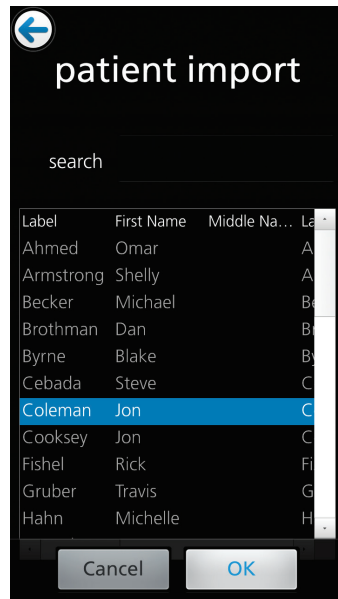
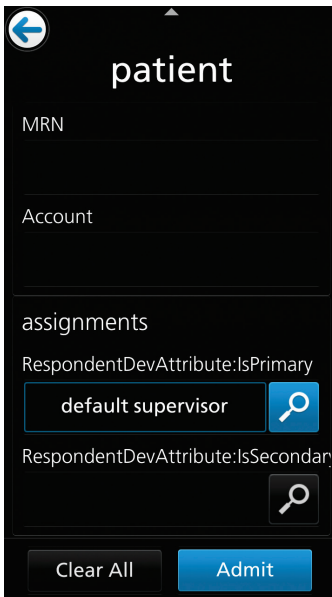

Fig. 2



- In the assignment section of the *Patient* menu (see Fig. 3), select the primary pager, then press *Admit*.

Fig. 3



Not Monitoring Message

When the sensor is off the patient for an extended period of time, a **Not Monitoring** message will appear on the screen. Acknowledge the message by pressing *Cancel* or *Discharge*. Press *Discharge* to discharge the patient that is currently admitted on Rad-97, or press *Cancel* to keep the same patient admitted.

Monitoring Resumed Message

When the sensor is taken off and placed back onto a patient, a **Monitoring Resumed** message will appear on the Rad-97 screen.

If this is a new patient, press *Discharge* to discharge the previous patient. If the same patient is being monitored, press *Confirm* to continue monitoring the same patient.

Discharging a Patient

1. Press the *Discharge* icon  on the bottom left of the screen to open the *Patient* screen.
2. Select the *Discharge* button on the bottom of the screen (see Fig. 4).
3. A confirmation message will appear (see Fig. 5).
4. Press *Discharge* to complete the discharge procedure.

Fig. 4

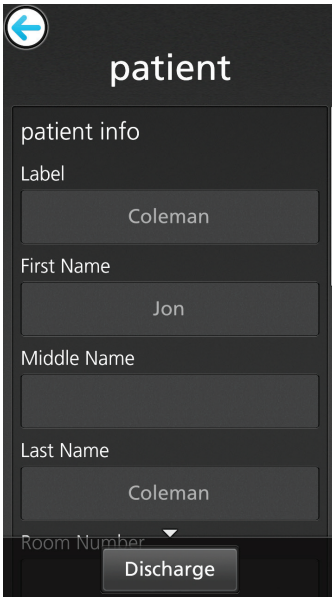
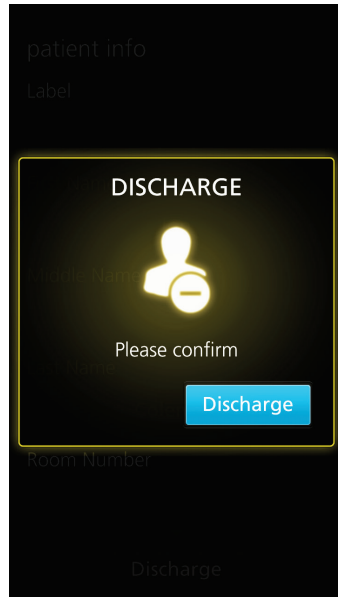

Fig. 5



Chapter 8: Third-Party Devices

Flexible measurement expansion is possible through the Rad-97 Bluetooth connection. Rad-97 can display parameters and measurements captured by third-party technologies in an all-in-one view on Rad-97.

When a third-party device is connected, Rad-97 automatically creates a window that displays all the data from that device on the *Main Screen*.

Connect Device to Rad-97

To connect a third-party device to Rad-97 using Bluetooth, perform the following:

1. Ensure Bluetooth is enabled on Rad-97. See **Bluetooth** on page 92.
2. Ensure Bluetooth is enabled on the third-party device; refer to the third-party device's *Operator's Manual* if needed.
3. Rad-97 will automatically connect to the device.
4. The third-party device can now be used with Rad-97. Refer to the third-party device's *Operator's Manual* for proper operation.

Chapter 9: Alarms and Messages

The following chapter contains information about alarms and messages.

For more information, see **Chapter 10: Troubleshooting** on page 137.

Alarm Interface

Alarms can have different priority levels and come from different sources. The following tables describe alarm behaviors in more detail.

Priority	Alarm Sound
High	10-pulse burst
Medium	3-pulse burst

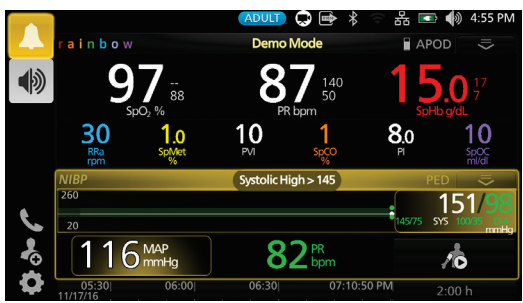

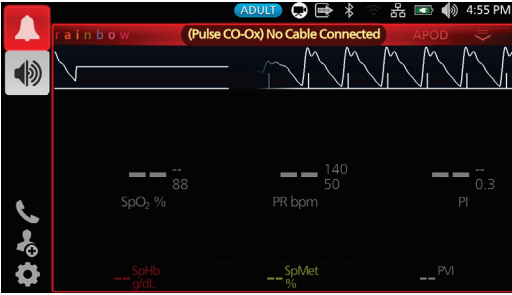

Alarm Source/Example	Explanation
	<p>Parameter Level: The example shown here is a PR alarm (PR Low) as the reading exceeds the lower alarm limit. Note that the PR parameter as well as the Window are illuminated red, and the explanation of the alarm is shown at the top of the Window (PR Low).</p>
	<p>Window Level: The example shown here is an alarm in the lower NIBP Window. Note that the border of the Window illuminates yellow, and the explanation of the alarm is shown at the top of the Window (Systolic High).</p>

Alarm Source/Example	Explanation
	<p>System Level: The example shown here is a "No Cable Connected" alarm. Note that the border of the entire Rad-97 display is illuminated, and the explanation of the alarm is shown in the Status Bar (No Cable Connected).</p>

About Alarms

The *Alarm Silence* icon is an indicator as well as a functional button. It always indicates the presence of alarms, and it can be used to temporarily suspend audible alarms for a pre-configured amount of time (Silence Duration).

Silence Duration configurations vary across different parameters and measurements. For more information about Silence Duration, refer to **rainbow Parameter Settings** on page 59.

Icon Appearance	Description	Visual Alarms
	<p>There are currently no active alarms, and no alarms have been silenced.</p>	<p>No</p>
	<p>There are currently no active alarms, but at least one alarm has been and is still silenced.</p>	<p>No</p>
	<p>There is currently at least one active alarm that has not been silenced.</p>	<p>Yes</p>
	<p>There is currently at least one active alarm, but all active alarms are silenced.</p>	<p>Yes</p>

Silencing Alarms

Alarms are conveyed in several ways: audibly, visibly, or both ways simultaneously.

To silence or dismiss alarms:

- Touch *Silence* in the highlighted area of the Status Bar or the *Alarm Silence* button.
- If the alarm is for a specific parameter, touch the alarming parameter. Parameters are highlighted when in an alarm state.
- Audible alarms that are temporarily suspended by pressing the *Alarm Silence* button can be unsususpended by pressing the *Alarm Silence* button again.

The following is an example of a visual alarm:

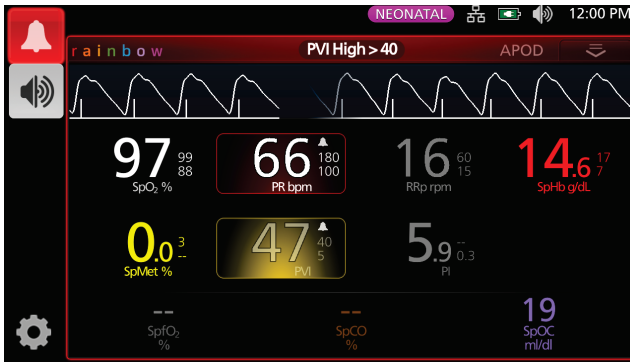

The following is an example of a typical medium priority alarm due to parameter limit violation.

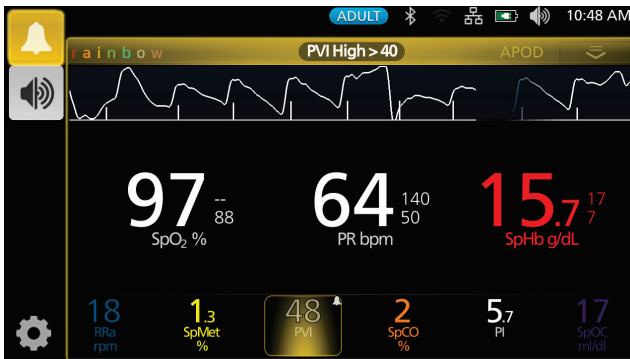

To silence audible alarms

Touch the *Alarm Silence* icon or the highlighted value once to silence the audible alarm.

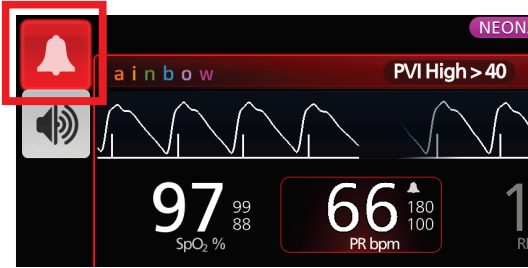

The audible alarm is silenced for the Silence Duration. A countdown timer will display as shown below.

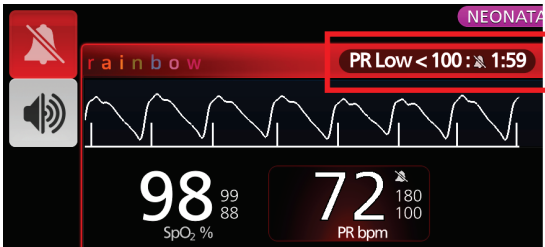

The length of time that a parameter limit audible alarm remains silenced can be changed using the Silence Duration feature located in the *Alarms* menu for each parameter.

Audio Pause

Audio Pause temporarily suspends all audible alarms on Rad-97. When it is active, visual alarms are not impacted and will still display. The Audio Pause icon is located on the left side of the Status Bar; do not confuse it with the Sounds icon on the right side of the Status Bar. See **About the Status Bar** on page 49.

By default, Audio Pause is inactive (alarms audible), and the icon appears in as follows:



To activate Audio Pause, press the icon. It will turn red and the remaining Audio Pause Duration time counts down next to the icon. The default duration for Audio Pause is 120

seconds. In the example below, Audio Pause is activated, and there are 15 seconds left until Audio Pause is inactive again (alarms audible again).



To configure Audio Pause, see **Sounds** on page 85.

Note: When Audio Pause is activated, powering off and then powering on Rad-97 will return Audio Pause to its default inactive state.

Adaptive Threshold Alarm (ATA) Feature

ATA is currently not available in the U.S.A. and territories relying on FDA market clearance.

Adaptive Threshold Alarm (ATA) is a user-selectable feature that is intended to provide adaptive alarm thresholds in order to reduce occurrences of unnecessary audible alarms while providing continuous SpO₂ surveillance.

ATA operates by utilizing alarm thresholds referenced to the patient-specific baseline value of the SpO₂ parameter. The alarm thresholds are intended to supplement the standard SpO₂ low alarm limit and the Rapid Desat low alarm limit.

SpO₂ values that fall below the Rapid Desat low alarm limit, whether occurring rapidly or not, will activate an audible alarm. When ATA is enabled, the Rapid Desat low alarm limit is always active; SpO₂ values that fall below the standard low alarm limit but remain above the ATA low alarm threshold activates visual alarms and a temporary audible notification. If the ATA low alarm threshold is crossed, audible and visual alarms activate. In the event that the patient-specific baseline value trends continuously lower, the ATA low alarm threshold is limited by the Rapid Desat low alarm limit.

Prior to enabling ATA, review and select the appropriate standard low and Rapid Desat alarm limits.

Once enabled, ATA has the following automatic safety features:

Reminder Tones

If a patient's SpO₂ value drops below the standard low alarm limit set by the user, a visual alert will display and a reminder tone will repeat every 15 minutes as long as the condition persists. If the SpO₂ value drops below the ATA low alarm limit, an audible alarm will activate.

Rapid Desat Alarm Protection

The Rapid Desat feature is always active when ATA is enabled. This means that deep desaturations (5% or 10%) from the standard SpO₂ low alarm limit generate audible and visual alarms. When used with ATA, Rapid Desat also serves as absolute low alarm limit protection. SpO₂ values exceeding the Rapid Desat low alarm limit, whether rapid or not, will activate audible and visual alarms. The user can select a Rapid Desat default of 5% or 10% desaturation.

Note: ATA does not allow a Rapid Desat setting of 0%.

When ATA is turned *Off*, the device uses the standard alarm limits and standard alarm delays.

See **About Alarms** on page 124

See **SpO2 Alarms** on page 62

3D Alarms



3D Alarms, accessible from the Main Menu, include the following:



Desat Index on page 129



About Desat Index on page 128



Pi Delta on page 130



About Pi Delta on page 129

About Desat Index

The 3D Desat Index Alarm allows a clinician to request audible and visual alarms if a patient experiences a specified number of desaturations beyond a defined level from the patient's baseline saturation over a specific period of time.

Traditional high and low SpO₂ alarm limits alert clinicians to saturation levels that exceed user-selected thresholds. These thresholds are typically established to detect significant changes from patients' baseline saturation levels. However, in select patient populations, substantial desaturation events that remain above a typical low alarm limit threshold may be preceded by a cycle of smaller transient desaturations over a limited period of time. The ability to alert clinicians when a cycle of smaller transient desaturations occur may provide an earlier indication of a potential significant decline in patient status, allowing for more focused monitoring and/or a change in treatment.

To address the select patient populations in which detecting a cycle of transient desaturations may be helpful, set a 3D Desat Index Alarm.

To set a 3D Desat Index Alarm see **Desat Index** on page 129.

Desat Index

From the *Desat Index* menu screen, change any of the following options:

Options	Description	Factory Default Settings	User Configurable Settings
Delta	The change in saturation from the patient's baseline measurement.	4%	2% to 10%, in steps of 1%.
Time	The period of time in which saturation events that exceed the delta will be monitored.	1 hour	1 to 4 hours, in steps of 1 hour.
Number of Events	The number of desaturations exceeding the delta which will activate audible and visual alarms.	Off	Off, 1 to 24 desaturations in steps of 1.

About Pi Delta

The Perfusion Index (Pi) Delta Alarm allows a clinician to request audible and visual alarms if perfusion at the monitored site decreases by a specified level (delta) over a specific period of time.

Perfusion Index gives an indication of the level of perfusion at the monitored site. Rad-97 measures perfusion at the monitored SpO₂ site by comparing the pulsatile signal to the non-pulsatile signal, and expressing that ratio as a percentage. Pi has been clinically proven to be useful as a predictor of the level of illness in neonates and adults. It has also been shown that Pi may change dramatically in response to sympathetic changes caused by inhalational agents and pain stimulation.* If Pi decreases over time, there may be underlying physiological reasons that need to be addressed.

Pi Delta audibly and visually alerts the user to important changes in a patient's perfusion, as compared to the patient's baseline Pi rate. The baseline is set by Rad-97 once the user has enabled the alarm and represents 30 seconds of currently averaged Pi. To set a Pi Delta alarm, see **Pi Delta** on page 130. The feature includes a user-selectable Pi Delta Alarm. This allows the clinician to request an audible and visual alarm if perfusion at the monitored site decreases by a specified level (delta) over a specified window of time. Three of the variables are selectable by the user within established ranges as noted in Pi Delta Alarms.

*De Felice C, Latini G, Vacca P, Kopotic RJ. *The pulse oximeter perfusion index as a predictor for high illness severity in neonates. Eur J Pediatr. 2002; 161:561-562.*

Pi Delta

From the *Pi Delta* menu screen, change any of the following options:

Options	Description	Factory Default Settings	User Configurable Settings
Set Baseline	Sets the Perfusion Index (Pi) value to be used as the baseline.	Off	On or Off
Percent Change	The change in Pi from the baseline that, if maintained for the Timeout length, will trigger audible and visual alarms.	50%	10% to 99%, in steps of 1%
Timeout	The length of time over which the percent change in Pi is monitored.	None	None or 1, 5, 30 minutes, 1, 4, 8, 12, 24, 36, 48 hours

Messages

The following section lists common Rad-97 messages, potential causes, and next steps.

Message	Potential Causes	Next Steps
<i>(Pulse CO-Ox) Replace Cable</i> or <i>(RAM) Replace Cable</i>	<ul style="list-style-type: none"> The patient cable is non-functional or the patient monitoring time of the cable has expired. 	<ul style="list-style-type: none"> Replace the patient cable.
<i>(Pulse CO-Ox) Cable Near Expiration</i> or <i>(RAM) Cable Near Expiration</i>	<ul style="list-style-type: none"> Patient cable has less than 10% of patient monitoring time remaining. 	<ul style="list-style-type: none"> Replace with new patient cable.

Message	Potential Causes	Next Steps
<p><i>(Pulse CO-Ox) No Cable Connected</i></p> <p>or</p> <p><i>(RAM) No Cable Connected</i></p>	<ul style="list-style-type: none"> • Cable not attached or not fully inserted into the connector. 	<ul style="list-style-type: none"> • Disconnect and reconnect cable into connector.
<p><i>(Pulse CO-Ox) Incompatible Cable</i></p>	<ul style="list-style-type: none"> • Not a proper cable. 	<ul style="list-style-type: none"> • Replace with a proper cable.
<p><i>(Pulse CO-Ox) Replace Sensor</i></p> <p>or</p> <p><i>(RAM) Replace Sensor</i></p>	<ul style="list-style-type: none"> • Reusable sensor has used all its available patient monitoring time. • Sensor is non-functional. • Defective sensor. 	<ul style="list-style-type: none"> • Replace sensor.
<p><i>(Pulse CO-Ox) Sensor Near Expiration</i></p> <p>or</p> <p><i>(RAM) Sensor Near Expiration</i></p>	<ul style="list-style-type: none"> • Reusable sensor has less than 10% patient monitoring time remaining. 	<ul style="list-style-type: none"> • Replace with new reusable sensor.
<p><i>(Pulse CO-Ox) Adhesive Near Expiration</i></p> <p>or</p> <p><i>(RAM) Adhesive Near Expiration</i></p>	<ul style="list-style-type: none"> • Disposable sensor has less than 10% patient monitoring time remaining. 	<ul style="list-style-type: none"> • Replace with new disposable sensor.
<p><i>(Pulse CO-Ox) Incompatible Sensor</i></p> <p>or</p> <p><i>(RAM) Incompatible Sensor</i></p>	<ul style="list-style-type: none"> • Not a proper Masimo sensor. • Sensor is attached to a device without an appropriate parameter installed. 	<ul style="list-style-type: none"> • Replace with a proper Masimo sensor. • Use a compatible sensor. Contact your local Masimo Representative to learn more about optional parameter upgrades.

Message	Potential Causes	Next Steps
<p><i>(Pulse CO-Ox) Incompatible Adhesive Sensor</i></p> <p>or</p> <p><i>(RAM) Incompatible Adhesive Sensor</i></p>	<ul style="list-style-type: none"> • Not a proper Masimo sensor. • Sensor is attached to a device without an appropriate parameter installed. 	<ul style="list-style-type: none"> • Replace with a proper Masimo sensor. • Use a compatible sensor. Contact your local Masimo Representative to learn more about optional parameter upgrades.
<p><i>(Pulse CO-Ox) No Sensor Connected</i></p> <p>or</p> <p><i>(RAM) No Sensor Connected</i></p>	<ul style="list-style-type: none"> • Sensor not fully inserted into the connector. May be an incorrect sensor or a defective sensor or cable. • Device is searching for patient's pulse. • Sensor is disconnected from patient cable. Sensor connected upside down into patient cable. 	<ul style="list-style-type: none"> • Disconnect and reconnect sensor. See the instructions for use provided with the sensor. • Disconnect and reconnect the sensor into the Patient Cable connector. • Check to see if the sensor LED is flashing. Disconnect and reconnect the sensor. If the LED fails to operate, replace the sensor.
<p><i>(Pulse CO-Ox) Sensor Initializing</i></p>	<ul style="list-style-type: none"> • Device is checking the sensor for proper function and performance. 	<ul style="list-style-type: none"> • If values are not displayed within 30 seconds, disconnect and reconnect sensor. If values are still not displayed, replace with a new sensor.
<p><i>(Pulse CO-Ox) Sensor Off Patient</i></p> <p>or</p> <p><i>(RAM) Sensor Off Patient</i></p>	<ul style="list-style-type: none"> • Sensor off patient. • Sensor not connected to patient properly. Sensor is damaged. 	<ul style="list-style-type: none"> • Disconnect and reconnect sensor. • Reattach sensor. • Properly reapply the sensor to the patient and reconnect the sensor to the device or patient cable. If the sensor is damaged, replace the sensor.
<p><i>(RAM) RAM Check Sensor</i></p>	<ul style="list-style-type: none"> • RAM unable to collect data through RAM Sensor. 	<ul style="list-style-type: none"> • Ensure proper sensor application. Check that no object is pulling on the sensor cable, which may cause the sensor to peel off.

Message	Potential Causes	Next Steps
<i>(RAM) Sensor Initializing</i>	<ul style="list-style-type: none"> Device is checking the sensor for proper function and performance. 	<ul style="list-style-type: none"> If values are not displayed within 30 seconds, disconnect and reconnect sensor. If values are still not displayed, replace with a new sensor.
<i>(Pulse CO-Ox) Replace Adhesive Sensor</i> or <i>(RAM) Replace Adhesive Sensor</i>	<ul style="list-style-type: none"> When a single-patient-use sensor is used, the adhesive portion of the sensor is non-functional, or the life of the adhesive portion of the sensor has expired. 	<ul style="list-style-type: none"> Replace the adhesive portion of the sensor.
<i>(Pulse CO-Ox) No Adhesive Sensor Connected</i> or <i>(RAM) No Adhesive Sensor Connected</i>	<ul style="list-style-type: none"> When a single-patient-use sensor is used, the adhesive portion of the sensor is not connected. 	<ul style="list-style-type: none"> Ensure the adhesive portion is firmly connected to the sensor.
<i>(Pulse CO-Ox) Low Perfusion Index</i>	<ul style="list-style-type: none"> Signal strength is too weak. 	<ul style="list-style-type: none"> Move sensor to better perfused site. See Troubleshooting Measurements on page 137.
<i>(Pulse CO-Ox) Low Signal IQ</i>	<ul style="list-style-type: none"> Indicates low signal confidence in the value displayed due to poor signal strength. 	<ul style="list-style-type: none"> Ensure proper sensor application. Move sensor to a better perfused site. See Signal IQ Indicators on page 79.
<i>(Pulse CO-Ox) Pulse Search</i>	<ul style="list-style-type: none"> Device is searching for pulse. 	<ul style="list-style-type: none"> If device fails to display within 30 seconds, disconnect and reconnect. If pulse search continues, move sensor to better perfused site.

Message	Potential Causes	Next Steps
(Pulse CO-Ox) Interference Detected or (RAM) Interference Detected	<ul style="list-style-type: none"> High intensity light (pulsating strobe lights, excessive ambient light sources such as surgical lights or direct sunlight) or other monitor displays. Incorrect monitor line frequency setting (Hz). 	<ul style="list-style-type: none"> Place a Masimo Optical Light Shield over the sensor. Adjust the Line Frequency to the correct Hz setting. See Device Settings on page 86.
(Pulse CO-Ox) SpO ₂ Only Mode	<ul style="list-style-type: none"> Occurs during an unsuccessful sensor initialization/pulse search routine or during monitoring. 	<ul style="list-style-type: none"> See the Directions for Use provided with your sensor. Use a Masimo light shield to cover the sensor and adjust the sensor.
Low SpCO SIQ	<ul style="list-style-type: none"> Indicates low signal confidence in the SpCO measurement displayed. 	<ul style="list-style-type: none"> Ensure proper sensor application. Check sensor to see if it is working properly. If not, replace the sensor. See Successful Monitoring for SpCO on page 30.
Low SpMet SIQ	<ul style="list-style-type: none"> Indicates low signal quality of SpMet measurement. 	<ul style="list-style-type: none"> Ensure proper sensor application. Check sensor to see if it is working properly. If not, replace the sensor. See Successful Monitoring for SpMet on page 30.
Low SpHb SIQ	<ul style="list-style-type: none"> Indicates low signal quality of SpHb measurement. 	<ul style="list-style-type: none"> Ensure proper sensor application. Check sensor to see if it is working properly. If not, replace the sensor. See Successful Monitoring for SpHb on page 29.
"- -" (Dashes shown as parameter value)	<ul style="list-style-type: none"> Unable to provide a parameter value. 	<ul style="list-style-type: none"> Check patient's vital condition.
Low Battery	<ul style="list-style-type: none"> Battery charge is low. 	<ul style="list-style-type: none"> Charge battery by powering the device with AC line power.
Speaker Failure	<ul style="list-style-type: none"> Device requires service. 	<ul style="list-style-type: none"> Contact Masimo Tech Support. See Chapter 12: Service and Maintenance on page 167.

Message	Potential Causes	Next Steps
<i>RTC Battery Low</i>	<ul style="list-style-type: none"> Device requires service. 	<ul style="list-style-type: none"> Contact Masimo Technical Support. See Chapter 12: Service and Maintenance on page 167.

Noninvasive Blood Pressure (NIBP) Messages

The following section lists common NIBP messages, their potential causes, and next steps.

Message	Potential Causes	Next Steps
<i>Check Cuff (Weak Signal)</i>	<ul style="list-style-type: none"> Weak or no signal measured during blood pressure measurement. 	<ul style="list-style-type: none"> Check that the hose is connected. Check that the correct size cuff is being applied. Check that the cuff is in the correct position. Check that there is no excessive clothing between arm and cuff. Retake another measurement. Check that the cuff is not leaking air. If problem still persists, contact Customer Service.
<i>Check Cuff (Artifact)</i>	<ul style="list-style-type: none"> Motion may be affecting ability to take measurement. 	
<i>Check Cuff (Out of Range)</i>	<ul style="list-style-type: none"> Measurement is out of range. 	
<i>Check Cuff (Measurement Timeout)</i>	<ul style="list-style-type: none"> Weak signal when measurement is being taken. 	
<i>Check Cuff (Pneumatic Blockage)</i>	<ul style="list-style-type: none"> May be a blockage in the air hose. 	
<i>Check Cuff (Inflate Timeout)</i>	<ul style="list-style-type: none"> May be a blockage in the air hose. 	
<i>Check Cuff (Safety Timeout)</i>	<ul style="list-style-type: none"> Weak signal when measurement is being taken. 	
<i>Check Cuff (Overpressure)</i>	<ul style="list-style-type: none"> May be due to a faulty cuff. 	

Message	Potential Causes	Next Steps
<i>Calibration Required</i>	<ul style="list-style-type: none"> Blood pressure measurement transducer may be out of range or there has been a calibration data failure. 	<ul style="list-style-type: none"> Perform calibration procedures. See Chapter 12: Service and Maintenance on page 167. If problem still persists, contact Masimo Technical Support.
<i>Module Error</i>	<ul style="list-style-type: none"> Device requires service. 	<ul style="list-style-type: none"> Contact Masimo Technical Support. See Chapter 12: Service and Maintenance on page 167.

Chapter 10: Troubleshooting

Troubleshooting Measurements

The following section lists possible measurement symptoms, the potential cause, and next steps.

For additional information, see **Safety Information, Warnings and Cautions** on page 13.

Symptom	Potential Causes	Next Steps
<i>Low SIQ message displayed (Low signal quality).</i>	<ul style="list-style-type: none">• Sensor is damaged or not functioning.• Improper sensor type or application.• Excessive motion.• Low perfusion.	<ul style="list-style-type: none">• Verify Sensor type and size and re-apply sensor. See <i>Directions for Use</i> for Sensor.• Check if blood flow to the sensor site is restricted.• Check the placement of the sensor. Re-apply sensor or move to a different site.• Replace sensor.• Minimize or eliminate motion at the monitoring site.• Set to Maximum Sensitivity. See Sensitivity Modes Overview on page 52.

Symptom	Potential Causes	Next Steps
<i>Difficulty obtaining a reading.</i>	<ul style="list-style-type: none"> • Inappropriate sensor or sensor size. • Improper sensor type or application. • Low perfusion. • Excessive motion artifact. • Excessive ambient or strobing light. • Low battery/ not plugged into AC power supply. • Interference from line frequency-induced noise. 	<ul style="list-style-type: none"> • Allow time for parameter reading to stabilize. • Verify sensor type and size and re-apply sensor. See <i>Directions for Use</i> for sensor. • Check if blood flow to the sensor site is restricted. • Check the placement of the sensor. Re-apply sensor or move to a different site. • Replace sensor. • Verify the device and sensor are configured with the parameter. • Verify proper sensor and sensor size for the patient. • Shield the sensor from excessive or strobing light. • Minimize or eliminate motion at the monitoring site. • Connect AC power supply. • Verify and set 50 or 60Hz menu setting. See Localization on page 87.
<i>Parameter readings displayed as dashes.</i>	<ul style="list-style-type: none"> • Parameter may not have stabilized. • Device may not be configured with the parameter. • Sensor is not compatible with the parameter. 	<ul style="list-style-type: none"> • Allow time for parameter reading to stabilize. • Verify sensor type and size and re-apply sensor. See <i>Directions for Use</i> for sensor. • Check if blood flow to the sensor site is restricted. • Check the placement of the sensor. Re-apply sensor or move to a different site. • Replace sensor. • Verify the device and sensor are configured with the parameter.

Symptom	Potential Causes	Next Steps
<i>Dimly Lit Parameters</i>	<ul style="list-style-type: none"> • Low signal quality. 	<ul style="list-style-type: none"> • Assess the patient. • Verify sensor type and size and re-apply sensor. See <i>Directions for Use</i> for sensor. • Check if blood flow to the sensor site is restricted. • Check the placement of the sensor. Re-apply sensor or move to a different site. • Replace sensor. • Minimize or eliminate motion at the monitoring site. • Set to MAX Sensitivity. See <i>Sensitivity Modes Overview</i> on page 52.
<i>Parameter Values Do Not Correlate With Clinical Assessment or Arterial Blood Gas Measurements</i>	<ul style="list-style-type: none"> • Low perfusion. • Sensor displacement. 	<ul style="list-style-type: none"> • Check for error messages. See <i>Chapter 9: Alarms and Messages</i> on page 123. • Check placement of sensor or if it is too tight. Reapply sensor or select a new site. Set to MAX sensitivity and confirm that the sensor is securely placed on the patient. See <i>Directions for Use</i> for sensor.
<i>Unexpected Parameter Readings</i>	<ul style="list-style-type: none"> • Low SIQ or Pi values. • Inappropriate sensor size or sensor measurement location. 	<ul style="list-style-type: none"> • Reposition sensor to site with strong SIQ and Pi. Average readings taken from three different sites to improve accuracy. Submit blood sample for laboratory CO-Oximetry test for comparison. • Verify proper sensor for patient size. Verify proper sensor site. See <i>Directions for Use</i> for sensor.

Troubleshooting Rad-97

The following section lists possible Rad-97 symptoms, potential causes, and next steps.

For more information, see **Chapter 9: Alarms and Messages** on page 123.

Symptom	Potential Causes	Next Steps
<i>Device does not turn on</i>	<ul style="list-style-type: none"> Depleted Battery. Internal failure. 	<ul style="list-style-type: none"> Check AC Power connection. Contact Masimo Service. See Contacting Masimo on page 173.
<i>System failure technical alarm active</i>	<ul style="list-style-type: none"> Internal failure. 	<ul style="list-style-type: none"> Turn Rad-97 Off and On. Contact Masimo service. See Contacting Masimo on page 173.
<i>Speaker does not work</i>	<ul style="list-style-type: none"> Device audible settings may be incorrect. Internal failure. 	<ul style="list-style-type: none"> Turn Rad-97 Off and On. Check that <i>Alarms</i> and <i>Sounds</i> have not been silenced. Check that <i>Alarms</i> and <i>Sounds</i> volumes settings. Check the device is not in <i>All Mute</i>. Check that the device speaker is not being muffled. Contact Masimo service. See Contacting Masimo on page 173.

Symptom	Potential Causes	Next Steps
<i>Device screen is blank</i>	<ul style="list-style-type: none"> • The device is Off. • The brightness display is not correct. • Battery may be depleted. • Internal failure. 	<ul style="list-style-type: none"> • Turn Rad-97 Off and On. • Adjust the brightness setting. See Brightness on page 94. • Check AC power connection. • Contact Masimo service. See Contacting Masimo on page 173.
<i>Touchscreen/Buttons do not respond when pressed</i>	<ul style="list-style-type: none"> • EMI (Electro Magnetic Interference). • Internal failure. 	<ul style="list-style-type: none"> • Check device AC power is properly grounded. • Relocate the device from other devices that may cause electromagnetic interference. • Contact Masimo service. See Contacting Masimo on page 173.
<i>Battery run time significantly reduced</i>	<ul style="list-style-type: none"> • Battery not fully charged. • Battery damaged. • Battery capacity effected. 	<ul style="list-style-type: none"> • Check battery charge level indicator. • Check battery is fully charged. • Contact Masimo service. See Contacting Masimo on page 173.
<i>Device does not detect that patient cable is connected</i>	<ul style="list-style-type: none"> • Cable connector not properly connected to the device. • Damaged connector. • Damaged cable. • Cable expired. • Internal failure. 	<ul style="list-style-type: none"> • Remove and reconnect cable. • Ensure the connector is fully connected to the device. • Replace cable. • Contact Masimo service. See Contacting Masimo on page 173.

Symptom	Potential Causes	Next Steps
<i>Device does not detect that the sensor is connected</i>	<ul style="list-style-type: none"> • Sensor not properly connected to device. • Improper placement of sensor. • Damaged sensor. • Sensor expired. • Internal failure. 	<ul style="list-style-type: none"> • Remove and reconnect sensor. • Ensure the connector is fully connected to the device. • Reapply sensor to the patient. Refer to sensor <i>Directions For Use</i>. • Replace sensor. • Turn Rad-97 Off and On. • Contact Masimo service. See Contacting Masimo on page 173.
<i>Nurse Call does not work</i>	<ul style="list-style-type: none"> • Nurse call connector not properly connected to the device. • Nurse call port not configured correctly. • Nurse call system not available. • Internal failure. 	<ul style="list-style-type: none"> • Check Nurse call connector is fully connected to the device. • Check Nurse call port configuration. See Device Output on page 96. • Check Nurse call system availability. • Contact Masimo service. See Contacting Masimo on page 173.
<i>Device does not communicate to other external devices through wired connection</i>	<ul style="list-style-type: none"> • External device is not compatible. • Device port settings are not configured correctly. • Communication cable is not properly connected. • Connected network is not available. • Internal failure. 	<ul style="list-style-type: none"> • Check external device compatibility. • Check device data port settings. See Device Output on page 96. • Check communication cable connection. • Check connected network settings and availability. • Contact Masimo service. See Contacting Masimo on page 173.

Symptom	Potential Causes	Next Steps
<p><i>Device does not communicate to other external devices through wireless connection</i></p>	<ul style="list-style-type: none"> • External device is not compatible. • Wi-Fi is not turned on and/or not correctly configured. • Location does not have wireless availability. • Connected network is not available. • Internal failure. 	<ul style="list-style-type: none"> • Check external device compatibility. • Check that the wireless feature is on and correctly configured. See <i>Wi-Fi</i> on page 92. • Check wireless availability for location. • Check network settings and availability. • Contact Masimo service. See <i>Contacting Masimo</i> on page 173.

Chapter 11: Specifications

The following chapter contains specifications for the Rad-97.

Pulse CO-Oximetry Specifications

Display Range

Measurement	Display Range
SpO ₂ (Functional Oxygen Saturation)	0% to 100%
PR (Pulse Rate)	0 bpm to 240 bpm
Pi (Perfusion Index)	0.00 to 0.99
PVi (Pleth Variability Index)	0 to 100
RRa (Respiration Rate)	0 rpm* to 70 rpm*
SpHb (Hemoglobin)	0.0 g/dL to 25.0 g/dL 0 g/L to 250 g/L 0.0 mmol/L to 15.5 mmol/L
SpCO (Carboxyhemoglobin)	0% to 99%
SpMet (Methemoglobin)	0.0% to 99.9%
SpOC (Oxygen Content)	0 ml/dl to 35 ml/dl
ORi (Oxygen Reserve index)**	0.00 to 0.99
RRp (Respiration Rate)**	0 rpm to 70 rpm

* Breaths per minute is denoted as rpm on device display.

** Parameter currently not available in the U.S.A. and territories relying on FDA market clearance.

Accuracy (ARMS*)

Oxygen Saturation (SpO₂)		
No Motion [1] (SpO ₂ from 60% to 80%)	Adults, Pediatrics, Infants	3%
No Motion [2] (SpO ₂ from 70% to 100%)	Adults, Pediatrics, Infants	2%
	Neonates	3%
Motion [3] (SpO ₂ from 70% to 100%)	All patient populations	3%
Low perfusion [4] (SpO ₂ from 70% to 100%)	All patient populations	2%
Pulse Rate (PR)		
Range	25 to 240 bpm	
No motion	All patient populations	3 bpm
Motion [5]	All patient populations	5 bpm
Low Perfusion	All patient populations	3 bpm
Upper and Lower Limits of Agreement (LoA)**		
Upper 95% LoA [6]		3%
Lower 95% LoA [6]		-3%

Carboxyhemoglobin Level (SpCO) [1]		
Range of 1% to 40%	Adults, Pediatrics, Infants	3%
Methemoglobin Level (SpMet) [1]		
Range 1% to 15%	All patient populations	1%
Total Hemoglobin (SpHb) [7]		
Range of 8 g/dL to 17 g/dL	Adults, Pediatrics	1 g/dL
Respiratory Rate (RRa) [8]		
Range of 4 to 70 bpm***	Adults, Pediatrics	1 bpm
Respiratory Rate (RRp)**** [8]		
Range of 4 to 70 rpm	Adults, Pediatrics	1 rpm

* A_{RMS} accuracy is a statistical calculation of the difference between device measurements and reference measurements. Approximately two-thirds of the device measurements fell within $\pm A_{RMS}$ of the reference measurements in a controlled study.

** See Bland and Altman. Agreement between methods of measurement with multiple observations per individual. *Journal of Biopharmaceutical Statistics* (2007) vol. 17 pp. 571-582.

*** Breaths per minute is denoted as rpm on device display.

****Parameter currently not available in the U.S.A. and territories relying on FDA market clearance.

Note: A functional tester cannot be used to assess the accuracy of Rad-97.

SpO₂ Performance Specifications

Accuracy testing for SpO₂ was performed on healthy adult subjects. The tables below provides A_{RMS} (Accuracy Root Mean Square) values measured using the Masimo Rainbow SET Technology with Masimo RD SET disposable sensors in clinical studies under no motion conditions. The Bland-Altman plots provided in the operator's manual are for the sensors identified in the respective plots. Bland-Altman plots for sensors not listed in the tables below are available in the Directions for Use (DFU) for those sensors. See the sensor DFU for the Bland-Altman plots for the respective compatible sensor.

Measurement A_{RMS} Values for Disposable (RD SET Series) Sensors	
SpO ₂ Accuracy Range (%)	A_{RMS} (%)
70-80	1.4
80-90	1.6
90-100	1.1
70-100	1.4

The table below provides the upper 95% and lower 95% limits of agreement. The differences between measurements by the two methods are used to calculate the mean and standard deviation. The lower 95% limit of agreement is the mean minus 1.96 standard deviation and the upper 95% limit of agreement is the mean plus 1.96 standard deviation. These limits are expected to contain 95% of the differences between measurements between the two methods in controlled environments.

Upper and Lower Limits of Agreement (LoA)*	
Upper 95% LoA	3.15%
Lower 95% LoA	-2.21%

* See Bland and Altman. Agreement between methods of measurement with multiple observations per individual. *Journal of Biopharmaceutical Statistics* (2007) vol. 17 pp. 571-582.

The below Bland-Altman plot represents the correlation of the $(SpO_2 + SaO_2)/2$ versus $(SpO_2 - SaO_2)$ under no motion with an upper 95% and lower 95% limits of agreement.

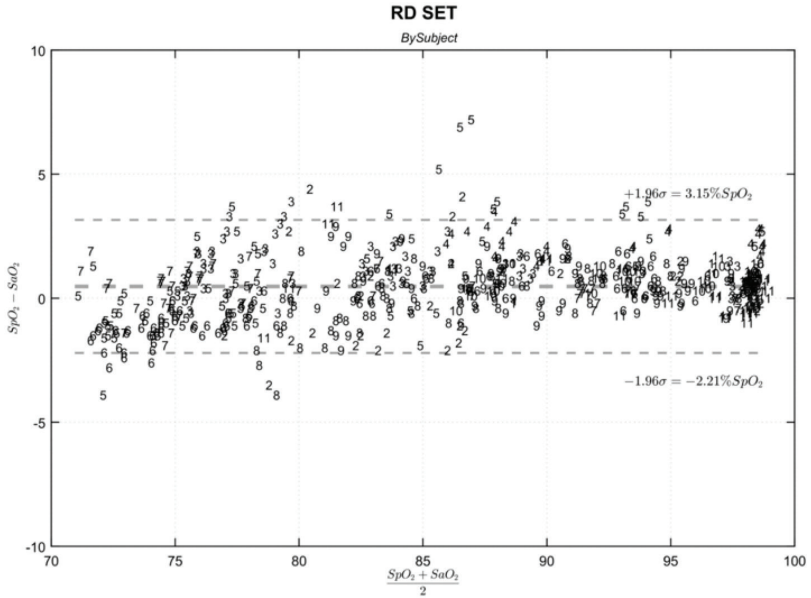

Figure 1: Disposable (RD SET Series) Sensors (ARMS 70-100%)

Resolution

Parameter	Resolution
SpO ₂	1%
PR	1 BPM
RRa	1 RPM*
SpHb	0.1 g/dL
	0.1 mmol/L
	1 g/L
SpCO	1%

Parameter	Resolution
SpMet	0.1%
SpOC	1.0 ml/dL
RRp**	1 RPM

* Breaths per minute is denoted as rpm on device display.

** Parameter currently not available in the U.S.A. and territories relying on FDA market clearance.

Noninvasive Blood Pressure (NIBP) Specifications

Measurement Range

Measurement	Patient Population	Display Range
Systolic	Adult	40-260 mmHg
	Pediatric	40-230 mmHg
	Neonatal	40-130 mmHg
Diastolic	Adult	20-200 mmHg
	Pediatric	20-160 mmHg
	Neonatal	20-100 mmHg
MAP	Adult	26-220 mmHg
	Pediatric	26-183 mmHg
	Neonatal	26-110 mmHg
Pulse Rate (PR)	All	30-220 bpm

Accuracy

Pressure Transducer	
Between 0 mmHg and 300 mmHg	±3mmHg

Pressure Range

Weight	Patient Category	Initial Pressurization	Maximum Pressure
Greater than 75 lbs (34 kg)	Adult	160 mmHg	280 mmHg
Between 15.4 - 75 lbs (7 - 34 kg)	Pediatric	140 mmHg	280 mmHg
Less than 15.4 lbs (7 kg)	Neonatal	90 mmHg	140 mmHg

Electrical

AC Power Requirements	
AC Power requirements	100 to 240 VAC, 47 to 63 Hz
Power consumption	60 VA
Fuses	UL, Metric (5x20mm), rated min. 250 VAC, 1 Amp, Time Delay, min.1500A breaking capacity

Battery	
Type	Lithium ion
Capacity	Approx. 4 hours [9]
Charging Time	6 hours [10]

Environmental

Environmental Conditions	
Operating Temperature	0°C to 35°C (32°F to 95°F)
Storage/Transport Temperature	-20°C to 60°C [11] (-4°F to 140°F)
Operating Humidity	
Non-NIBP	10% to 95%, non-condensing
NIBP	15% to 95%, non-condensing
Storage/Transport Humidity	
Non-NIBP	10% to 90%, non-condensing
NIBP	15% to 90%, non-condensing
Operating Atmospheric Pressure	540 mbar to 1,060 mbar (540 hPa to 1060 hPa)

Physical Characteristics

Physical Characteristics	
Dimensions	22.9 cm x 10.2 cm x 16.5 cm (9" x 4" x 6.5")
Weight	
Without NIBP	0.92 kg. (2.03 lbs.)
With NIBP	1.05 kg. (2.32 lbs.)

Alarms

Alarm Priority	Alarm Status Color	Audio Alarm Description
High Priority	Flashing red	571 Hz tone, 10-pulse burst, pulse spacing: 0.25s, 0.25s, 0.50s, 0.25s, repeat time:10s
Medium Priority	Flashing yellow	550 Hz tone, 3-pulse burst, pulse spacing: 0.375s, 0.375s, repeat time: 7s
Low Priority	Solid yellow	No audible alarms

Alarm Characteristic	Description
Alarm Volume*	High Priority: 75 dB (min) Medium Priority: 70 dB (min)

* When volume is set to the highest level.

Display Indicators

Item	Description
Trend Memory	Max of 96 hours at 2-second resolution
Display Update Rate	1 second
Type	Backlit Active Matrix TFT LCD
Pixels	720 dots x 1280 dots

Compliance

EMC Compliance
IEC 60601-1-2:2007, Class B
EN/ISO 80601-2-61:2011, Clause 202.6.2.3, 20 V/m

Safety Standards Compliance
ANSI/AAMI ES 60601-1:2005
CAN/CSA C22.2 No. 60601-1
IEC 62366
IEC 60601-1-6
IEC 60601-1:2005
IEC 60601-1-8
IEC 60601-1-11
IEC 60601-2-49
IEC 80601-2-30 (NIBP)
EN/ISO 80601-2-61:2011

Equipment Classification per IEC 60601-1	
Type of Protection	Class I (AC power)
	Internally powered (Battery power)
Degree of Protection of Electrical Shock	Defibrillation proof BF-Applied Part

Equipment Classification per IEC 60601-1	
Protection against harm from liquid ingress	IP22, Protection from ingress of particulates > than 12.5 mm and protection against vertically falling water drops when enclosure is tilted at 15 degrees.
Mode of Operation	Continuous operation

Connectors

Connector	Type
Ethernet	10/100 Mbps
Nurse Call	1/4 inch round female
USB	USB 2.0
NIBP Nib	Male Quick Connect

Wireless Specifications

Communication (Wi-Fi)	
Type	WLAN Radio: IEEE 802.11 a/b/g
Frequency	802.11a: 5180-5240 MHz, 5745-5825 MHz 802.11b/g: 2412-2484 MHz
Max Peak Output Power	WLAN 17 dBm
Classification of Output Power Rating	Conducted
Output Power Type	Fixed at the Factory
Modulation Types	OFDM, BPSK, CCK
Modulation Signals	Analog and Digital

Communication (Wi-Fi)	
Available Data Rates	802.11a - 6, 9, 12, 18, 24, 36, 48, 54 Mbps. 802.11b - 1, 2, 5.5, 11 Mbps. 802.11g - 6, 9, 12, 18, 24, 36, 48, 54 Mbps.

Communication (Bluetooth)	
Type	Bluetooth
Frequency	2402-2480 MHz
Max Peak Output Power	Bluetooth 1.3 dBm
Classification of Output Power Rating	Conducted
Output Power Type	Fixed at the Factory
Modulation Types	DH5
Modulation Signals	Analog and Digital
Available Data Rates	Bluetooth 1 Mbps

Security and Authentication	
Encryption	64/128-bit WEP, Dynamic WEP, WPA-TKIP, WPA2-AES
Authentication	Open System, Shared Key, Pre-Shared Key (PSK), 802.1X: LEAP, PEAP< TTLS, TLS, EAP-FAST

Radio Compliance	
USA	FCC ID: VKF-MWM1 Model - RAD-97
Canada	IC:7362A-MWM1 IC Model: MWM1 RSS-210
Europe	EN 300 328 EN 301 893 EN 301 489-1 EN 301 489-17 R & TTE Directive
Japan	TELEC

Guidance and Manufacturer's Declaration-Electromagnetic Emissions

Guidance and Manufacturer's Declarations - Electromagnetic Emissions		
The ME Equipment is intended for use in the electromagnetic environment specified below. The customer or the user of the ME Equipment should assure that it is used in such an environment.		
Emission Test	Compliance	Electromagnetic Environment - Guidance
RF Emissions CISPR 11	Group 1	ME Equipment uses RF energy only for its internal function. Therefore, its RF emissions are very low and are not likely to cause any interference in nearby electronic equipment.
RF Emissions CISPR 11	Class B	Suitable for use in all establishments, including domestic environments and those directly connected to the public low-voltage power supply network that supplies buildings used for domestic purposes.
Harmonic Emissions IEC 61000-3-2	Class A	
Voltage fluctuations/ Flicker emissions IEC 61000-3-3	Complies	

Guidance and Manufacturer's Declaration-Electromagnetic Immunity

Guidance and Manufacturer's Declaration - Electromagnetic Immunity			
The ME Equipment is intended for use in the electromagnetic environment specified below. The customer or the user of the ME Equipment should assure that it is used in such an environment.			
Immunity Test	IEC 60601 Test Level	Compliance Level	Electromagnetic Environment - Guidance
Electrostatic discharge (ESD)	+6 kV contact	+6 kV contact +8 kV air	Floors should be wood, concrete, or ceramic tile. If floors are covered with synthetic material, the relative

Guidance and Manufacturer's Declaration - Electromagnetic Immunity			
IEC 61000-4-2	+8 kV air		humidity should be at least 30%.
Electrical fast transient/ burst IEC 61000-4-4	+/- 2 kV for power lines +/- 1 kV for input/output lines	+/- 2 kV for power lines +/- 1 kV for input/output lines	Mains power quality should be that of a typical commercial or hospital environment.
Surge IEC 61000-4-5	+/-1 kV line(s) to line(s) +/- 2 kV line(s) to earth	+/-1 kV line(s) to line(s) +/- 2 kV line(s) to earth	Mains power quality should be that of a typical commercial or hospital environment.
Voltage dips, short interruptions, and voltage variations on power supply input lines	100% dip in mains voltage for 0.5 cycle 60% dip in mains voltage for 5 cycle 30% dip in mains voltage for 25 cycle	100% dip in mains voltage for 0.5 cycle 60% dip in mains voltage for 5 cycle 30% dip in mains voltage for 25 cycle	Mains power quality should be that of a typical commercial or hospital environment.
Power frequency (50 / 60 Hz) magnetic field. IEC 61000-4-8	3 A/m	3 A/m	Power frequency magnetic fields should be at levels characteristic of typical location in a typical hospital environment.
			Portable and mobile RF communications equipment should be used no closer to any part of the ME Equipment, including cables, than the recommended separation distance calculated from the equation applicable to the frequency of the transmitter. Recommended separation distance

















Guidance and Manufacturer's Declaration - Electromagnetic Immunity			
Conducted RF IEC 61000-4-6	3 Vrms	3 Vrms	$d = \left[\frac{3,5}{V_1} \right] \sqrt{P}$
Radiated RF IEC 61000-4-3	20 V/m 80 MHz to 2.5 GHz	20 V/m	$d = \left[\frac{3,5}{E_1} \right] \sqrt{P}$ <p>80 MHz to 800 MHz</p> $d = \left[\frac{7}{E_1} \right] \sqrt{P}$ <p>800 MHz to 2.5 GHz</p> <p>where P is the maximum output power rating of the transmitter in watts (W) according to the transmitter manufacturer and d is the recommended separation distance in meters (m).</p> <p>Field strengths from fixed RF transmitters, as determined by an electromagnetic site survey, should be less than the compliance level in each frequency range^b.</p> <p>Interference may occur in the vicinity of equipment marked with the following symbol:</p> 
<p>Note 1: At 80 MHz and 800 MHz, the higher frequency range applies.</p> <p>Note 2: These guidelines may not apply in all situations. Electromagnetic propagation is affected by absorption and reflection from structures, objects and people.</p>			
<p>Field strengths from fixed transmitters, such as base stations for radio (cellular/cordless) telephones and land mobile radios, amateur radio, AM and FM radio broadcast and TV broadcast cannot be predicted theoretically with accuracy. To assess the electromagnetic environment due to fixed RF transmitters, an electromagnetic site survey should be considered. If the measured field strength in the location in which the ME Equipment is used exceeds the applicable RF compliance level above, the ME Equipment should be observed to verify normal operation. If abnormal performance is observed, additional measures may be necessary, such as re-orienting or relocating the ME Equipment.</p> <p>^b Over the frequency range 150 kHz to 80 MHz, field strengths should be less than [V1] V/m.</p>			

























Recommended Separation Distances









Recommended Separation Distance Between Portable and Mobile RF Communication Equipment and the ME Equipment			
The ME Equipment is intended for use in an electromagnetic environment in which radiated RF disturbances are controlled. The customer or the user of the ME Equipment can help prevent electromagnetic interference by maintaining a minimum distance between portable and mobile RF communications equipment (transmitters) and the ME Equipment as recommended below, according to the maximum output power of the communication equipment.			
Rated maximum output power of transmitter (W)	Separation Distance According to Frequency of Transmitter (m)		
	150 K Hz to 80 MHz $d = 1.17 \cdot \sqrt{P}$	80 MHz to 800 MHz $d = 0.18 \cdot \sqrt{P}$	800 MHz to 2.5GHz $d = 0.35 \cdot \sqrt{P}$
0.01	0.12	0.018	0.035
0.1	0.37	0.057	0.11
1	1.17	0.18	0.35
10	3.7	0.57	1.1
100	11.7	1.8	3.5
For transmitters rated at a maximum output power not listed above, the recommended separation distance d in meters (m) can be estimated using the equation applicable to the frequency of the transmitter, where P is the maximum output power rating of the transmitter in watts (W) according to the transmitter manufacturer.			
Note 1: At 80 MHz and 800 MHz, the higher frequency range applies.			
Note 2: These guidelines may not apply in all situations. Electromagnetic propagation is affected by absorption and reflection from structures, objects and people.			

Symbols

The following symbols may appear on the product or product labeling:

Symbol	Description	Symbol	Description
	Follow instructions for use		Consult instructions for use
	Mark of conformity to European medical device directive 93/42/EEC		ETL Intertek certification See Declarations on Page 1 for certifications
	Separate collection for electrical and electronic equipment (WEEE)		Non-Sterile
	Defibrillation-proof. Type BF applied part		NIBP
IP21	Protection from ingress of particulates > than 12.5 mm and against vertically falling water drops		Recyclable
	Authorized representative in the European community		Federal Communications Commission (FCC) Licensing
Rx ONLY	Caution: Federal (USA) law restricts this device to sale by or on the order of a physician	FCC ID:	Identifies unit has been registered as a radio device
	Non-ionizing electromagnetic radiation	IC Model:	Industry Canada Identification
	Warning, electricity		Biohazardous Waste
	Electrostatic		Not for continuous monitoring (No alarm for SpO ₂)

Symbol	Description	Symbol	Description
	No parameter alarms		Product contains no PVC (polyvinyl chloride) material
	Caution		Not made with natural rubber latex
	Manufacturer		Catalog number (model number)
	Date of manufacture YYYY-MM-DD		Masimo reference number
	Storage temperature range		Serial number
	Keep dry		Fragile, handle with care
	Storage humidity limitation		Do not use if package is damaged
	Atmospheric pressure limitation		Equipotential Ground Terminal
	Nurse Call Interface		AC current
	Fuse		Wireless Symbol level
	Stand-By		Wireless features can be used in member states with the restriction of indoor use in France -Class 2 wireless device
 RS-232	RS-232 Interface		Iris Connection

Symbol	Description	Symbol	Description
	Analog Out Interface		Ethernet
	Greater than		USB port
	Less than		China Restriction of Hazardous Substances
---	---		The names and content of the toxic and hazardous substances or elements shall be provided in the product instruction manual
	Instructions/Directions for Use/Manuals are available in electronic format @ http://www.Masimo.com/TechDocs Note: eIFU is not available for CE mark countries.		

Citations

[1] SpO₂, SpCO, and SpMet accuracy was determined by testing on healthy adult volunteers in the range 60% to 100% SpO₂, 0% to 40% SpCO, and 0% to 15% SpMet against a laboratory CO-Oximeter. SpO₂ and SpMet accuracy was determined on 16 neonatal NICU patients ranging in age from 7 days to 135 days old and weighing between 0.5 kg and 4.25 kg. Seventy-nine (79) data samples were collected over a range of 70% to 100% SaO₂ and 0.5% to 2.5% HbMet with a resultant accuracy of 2.9% SpO₂ and 0.9% SpMet. Contact Masimo for testing specifications.

[2] The Masimo rainbow SET technology with Masimo sensors has been validated for no motion accuracy in human blood studies on healthy adult male and female volunteers with light to dark skin pigmentation in induced hypoxia studies in the range of 70%-100% SpO₂ against a laboratory CO-Oximeter and ECG monitor.

[3] The Masimo rainbow SET technology with Masimo sensors has been validated for motion accuracy in human blood studies on healthy adult male and female volunteers with light to dark skin pigmentation in induced hypoxia studies while performing rubbing and touching motions, at 2 to 4 Hz at an amplitude of 1 to 2 cm and a non-repetitive motion between 1 to 5 Hz at an amplitude of 2 to 3 cm in induced hypoxia studies in the range of 70%-100% SpO₂ against a laboratory CO-Oximeter and ECG monitor.

[4] The Rad-97 has been validated for low perfusion accuracy in bench-top testing against a Biotek Index 2™ simulator and Masimo's simulator with signal strengths of greater than 0.02% and transmission of greater than 5% for saturations ranging from 70%-100%.

[5] Masimo rainbow SET technology with Masimo sensors has been validated for pulse rate accuracy for the range of 25-240 bpm in bench top testing against a Biotek Index 2 simulator.

[6] The differences between measurements by the two methods are used to calculate the mean and standard deviation. The lower 95% limit of agreement is the mean minus 1.96 standard deviation and the upper 95% limit of agreement is the mean plus 1.96 standard deviation. These limits are expected to contain 95% of the differences between measurements between the two methods in controlled environments. Accuracy testing for SpO₂ was performed on health adult subjects.

[7] SpHb accuracy has been validated on healthy adult male and female volunteers and on surgical patients with light to dark skin pigmentation in the range of 8 g/dL to 17 g/dL SpHb against a Coulter Counter. The SpHb accuracy has not been validated with motion or low perfusion.

[8] Respiration rate accuracy for the Masimo Acoustic Respiration Sensor and Instrument has been validated for the range of 4 to 70 respirations per minute in bench top testing. Clinical validation for up to 30 respirations per minute was also performed with the Masimo Acoustic Respiration sensor and instrument.

[9] This represents approximate run time with all connectivity options turned off and level 3 screen/key brightness using a fully charged battery.

[10] The battery recharge time shall be no longer than 6 hours at operating temperature of 25°C (77°F) ambient temperature and might not charge completely under elevated ambient temperature.

[11] If the batteries are to be stored for extended periods of time, it is recommended that they be stored between -20°C to +30°C, and at a relative humidity less than 85%. If stored for a prolonged period at environmental conditions beyond these limits, overall battery capacity may be diminished, and lifetime of the batteries may be shortened.

*Registered trademark of Fluke Biomedical Corporation, Everett, Washington.

Chapter 12: Service and Maintenance

The following chapter contains information about cleaning, battery operation, performance verification, service, repair, and warranty.

Cleaning

The Rad-97 is a reusable device. The device is supplied and is intended to be used non-sterile.

WARNING: To avoid electric shock, always turn off the Rad-97 and physically disconnect the AC power and all patient connections before cleaning.

CAUTION: To avoid permanent damage to the Rad-97, do not use undiluted bleach (5% - 5.25% sodium hypochlorite) or any other cleaning solution not recommended.

To surface clean the Rad-97:

- Wipe the outer surfaces using a dampened soft cloth with one of the recommended cleaning solutions twice or until the surfaces are free of any visible residue.

Note: Pay particular attention to cracks, crevices, and hard to reach areas of the device.

- Repeat the above cleaning step using a fresh wipe.
- Allow the Rad-97 to dry thoroughly before using again.

CAUTION: To avoid permanent damage to the Rad-97, do not use excessive amounts of liquids to clean the device.

The surfaces of the Rad-97 may be cleaned with the following solution(s):

- 70% Isopropyl Alcohol
- Cidex Plus (3.4% glutaraldehyde)
- 10% (1:10) chlorine bleach to water solution
- Quaternary ammonium chloride solution wipe

Nurse Call Setting Connections

For maximum flexibility, either normally open or normally closed signals are available. During an alarm condition or a low Signal IQ event, depending on the configuration of the device output, the normally open pin will be connected to the common pin and the normally closed pin will be disconnected. In addition, the Nurse Call Polarity can be inverted to accommodate various nurse call station requirements.

Only qualified personnel should connect one of these two signals to a hospital's Nurse Call system.

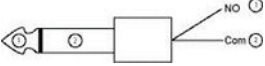
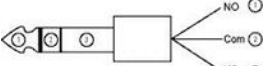
Cable Description	Nurse Call Event	Menu Setting
	2 contacts normally opened	Nurse Call Polarity Normal
	2 contacts normally closed	Nurse Call Polarity Inverse
	1 and 2 contacts normally opened 2 and 3 contacts normally closed	Nurse Call Polarity Normal
	1 and 2 contacts normally closed 2 and 3 contacts normally opened	Nurse Call Polarity Inverse

Performance Verification

Under normal operation, no internal adjustment or recalibration is required. Safety tests and internal adjustments should be done by qualified personnel only. Safety checks should be performed at regular intervals or in accordance with local and governmental regulations.

To test the performance of the Rad-97 following repairs or during routine maintenance, follow the procedure outlined in this chapter. If the Rad-97 fails any of the described tests, discontinue its use and correct the problem before returning the device back to the user.

Before performing the following tests, do the following:

- Connect the Rad-97 to AC power and fully charge the battery.
- Disconnect any patient cables or pulse oximetry probes from the front of the Rad-97.
- Disconnect nurse call, ethernet or USB cable from the rear of the Rad-97.

Power-On Self-Test

To conduct a Power-On Self-Test

1. Power on the device by pressing the home button.
2. Upon powering on, the device should emit a tone and the Masimo logo should display.

Note: If the Rad-97 does not pass the Power-On Self-Test, a system failure technical alarm will be activated. See **Chapter 10: Troubleshooting** on page 137.

Touchscreen Function Test

To conduct a Touchscreen Function Test

1. Connect the Rad-97 to AC power.
2. Perform the gestures outlined in *Touchscreen Function Test* on page 169.

Alarm Limit Test

Alarm Limit Test

1. Connect a sensor to the Rad-97. Place the sensor on a finger to obtain an SpO₂ value.
2. Change the High SpO₂ Alarm parameter to a value two points below the currently selected value. See *SpO₂ Alarms* on page 62.
3. Verify that the newly set parameter is shown on the *Display* screen.
4. Return the parameter to its original setting.
5. Repeat steps 1 to 3 for all active parameters.
6. Reset the alarm limits again to the original settings.

Testing with the optional Masimo SET Tester

To conduct a test with the optional Masimo SET® Tester

1. Turn off and then turn on the Rad-97.
2. Use the Patient Cable connector on the Rad-97 to connect the Masimo SET® Tester to the Rad-97.
3. See the directions for use that were provided with the Masimo SET® Tester.

Nurse Call Test

To conduct a Nurse Call test

1. Disconnect any patient cables, sensors, or accessories from the Rad-97.
2. Turn the Rad-97 Off and On again.
3. Ensure that there are no audible alarms or audible alarms that are not paused.
4. Verify the Nurse Call polarity is set to normal. See *Device Output* on page 96.
5. Connect one end of a Nurse Call interconnection cable with 1/4" round connector on each end to the nurse call port of the Rad-97. See *Back View* on page 37.
6. Connect the common lead of a digital multi-meter to the pin 12 of the Nurse Call (Common) connector on the Rad-97. Connect the positive lead of the digital multi-meter to pin 6 of the Nurse Call (Normally Open) connector and measure that the resistance is greater than 1 MW (open circuit).
7. Trigger an alarm on the monitor (for example, by disconnecting a sensor after it was measuring data). Verify that the resistance is less than 35 ohms.

Calibration

Noninvasive Blood Pressure

NIBP Module Calibration

Note: This section is provided as a reference and intended for qualified service professionals only.

Pass Criteria

International standards for automated NIBP devices require that the maximum static pressure accuracy shall be ± 3 mmHg or 2% or the reading, whichever is greater. This is a stringent requirement and all test equipment must be in excellent working order to properly perform this test. It is important to verify the calibration before changing it. Historical data has shown that the transducers rarely need to be re-calibrated although we still suggest that the calibration be verified annually.

Procedure

1. Enter NIBP menu, select "Calibration".
2. Enter password: 4258 and touch "Calibration Test".
3. Connect a manometer, volume and the hand bulb to the Module using "T" adapters and connection tubing.
4. Touch the "Test" button on the display to start the calibration.
5. Apply various pressures (between 0 mmHg and 280 mmHg) to the Module with the hand bulb. Verify that the Module pressure is equal to the manometer pressure (± 3 mmHg). If the Module pressure does not agree with the manometer pressure (± 3 mmHg), perform the Zero Point Calibration and the Span Point Calibration. Then perform this calibration again.
6. Calibration is now complete.

NIBP Air Leak Test

Note: This section is provided as a reference and intended for qualified service professionals only.

Pass Criteria

International standards for automated NIBP devices require that air leakage within the pneumatic system must not exceed 6 mmHg/minute.

Procedure

1. Connect the manometer and rigid volume (500 mL bottle) to the air hose connection using "T" adapters and connection tubing.
2. Enter NIBP menu, select "Calibration".
3. Enter password: 4258 and select "Air Leak Test".
4. Touch the "Test" button on the display to start the test.
5. Wait for the countdown timer to reach 0 second.

6. Check the "Result" section, if the leak rate is greater than 6 mmHg/min, contact customer service.

Zero Point Calibration

Note: This section is provided as a reference and intended for qualified service professionals only.

Calibration Steps

1. Enter NIBP menu, select "Calibration".
2. Enter password: 4258 and select "Zero Point Calibration".
3. Connect a manometer, volume and the hand bulb to the Module using "T" adapters and connection tubing.
4. Apply 0 (zero) mmHg to the module.
5. Touch the "Calibrate" to start the zero point calibration.
6. Results are displayed for Zero Point Calibration.
7. Calibration is completed.

Span Point Calibration

Note: This section is provided as a reference and intended for qualified service professionals only.

Calibration Steps

1. Enter NIBP menu and select "Calibration".
2. Enter password: 4258 and select "Span Point Calibration".
3. Connect a manometer, volume and the hand bulb to the Module using "T" adapters and connection tubing.
4. Apply 250 mmHg to the module.
5. Touch the "Calibrate" to start the span point calibration.
6. Results are displayed for Span Point Calibration.
7. Calibration is completed.

Overpressure Test

Note: This section is provided as a reference and intended for qualified service professionals only.

Note: This test is performed from the Main Screen.

Pass Criteria

International standards for automated NIBP devices require that the pressure must not exceed 300 mmHg on adults and pediatric patients and 150 mmHg on neonatal patients with a tolerance of 10% for 15 seconds or greater than 10% for 3 seconds. The overpressure pass criteria for the Advantage module are:

Adults, Pediatrics 300 ± 10mmHg

Neonates 150 ± 5mmHg

Test Method

The steps outlined below are for manually performing an overpressure test. Some or all of these steps may be incorporated into a service tool provided by the medical device manufacturer.

1. Set the corresponding patient profile. See **Chapter 5: Profiles** on page 103.
2. Perform an NiBP measurement.
3. Connect a manometer, volume and hand bulb to Module using "T" adapters.
4. From the Main Screen, touch the Start NIBP measurement button.
5. Touch the "Test" button on the display.
6. Increase the pressure to approximately 250mmHg using the hand bulb.
7. VERY SLOWLY increase the pressure from 280 to the overpressure point. Once it is reached, the valves will open and the pressure will rapidly reduce to 0mmHg.
8. If one of the overpressure values is not within the pass criteria above, return the module for service to an authorized service center.

Maintenance

Battery Operation and Maintenance

The Rad-97 includes a lithium ion rechargeable battery.

Before using the Rad-97 without the AC power connected, check the battery status indicator and ensure that the battery is fully charged. See **Battery Charge Status Indicator** on page 51.

To charge the Rad-97 battery, refer to **Initial Battery Charging** on page 41.

Note: When battery run time is significantly reduced, it is advisable to completely discharge and fully recharge the battery.

Run Time for Rad-97

The following table outlines the estimated minimum run time of the battery in the Rad-97.

- The time estimates are based on a fully charged battery.
- Time estimates are also based on specific operating modes.

For optimal battery run time, configure the device to automatically adjust the brightness. See **Brightness** on page 94.

Configuration	Operating Mode	Minimum run time (Est.)
Rad-97	<ul style="list-style-type: none"> • Not connected to AC power • Wireless connected • Bluetooth connected • Brightness level set to maximum 	2 hours

Repair Policy

Masimo or an authorized service department must perform warranty repair and service. Do not use malfunctioning equipment. Have the device repaired.

Clean contaminated and/or dirty equipment before returning, following the cleaning procedure described in **Cleaning** on page 167. Make sure the equipment is fully dry before packing.

To return the device for service, refer to **Return Procedure** on page 173.

Return Procedure

Clean contaminated/dirty equipment before returning, following instructions in **Cleaning** on page 167. Make sure the equipment is fully dry before packing. Call Masimo at 800-326-4890 and ask for Technical Support. Ask for an RMA number. Package the equipment securely, in the original shipping container if possible, and enclose or include the following information and items:

- A letter describing in detail any difficulties experienced with the Rad-97. Include the RMA number in the letter.
- Warranty information, a copy of the invoice or other applicable documentation must be included.
- Purchase order number to cover repair if the Rad-97 is not under warranty, or for tracking purposes if it is.
- Ship-to and bill-to information.
- Person (name, telephone/Telex/fax number, and country) to contact for any questions about the repairs.
- A certificate stating the Rad-97 has been decontaminated for bloodborne pathogens.
- Return the Rad-97 to the shipping address listed in **Contacting Masimo** on page 173 below.

Contacting Masimo

Masimo Corporation
40 Parker
Irvine, California 92618

Tel:+1 949 297 7000

Fax:+1 949 297 7001

Limited Warranty

Masimo warrants to the original end-user purchaser the Masimo-branded hardware product (Rad-97™ Pulse CO-Oximimeter®) and any software media contained in the original packaging

against defects in material and workmanship when used in accordance with Masimo's user manuals, technical specifications, and other Masimo published guidelines for a period of 12 months and any batteries for six (6) months from the original date the Product was obtained by the end-user purchaser.

Masimo's sole obligation under this warranty is the repair or replacement, at its option, of any defective Product or software media that is covered under the warranty.

To request a replacement under warranty, Purchaser must contact Masimo and obtain a returned goods authorization number so that Masimo can track the Product. If Masimo determines that a Product must be replaced under warranty, it will be replaced and the cost of shipment covered. All other shipping costs must be paid by purchaser.

Exclusions

The warranty does not apply to any non-Masimo branded product or any software, even if packaged with the Product, or any Product that was: (a) not new or in its original packaging when supplied to purchaser; (b) modified without Masimo's written permission; (c) supplies, devices, or systems external to the Product; (d) disassembled, reassembled, or repaired by anyone other than a person authorized by Masimo; (e) used with other products, like new sensors, reprocessed sensors, or other accessories, not intended by Masimo to be used with the Product; (f) not used or maintained as provided in the operator's manual or as otherwise provided in its labeling; (g) reprocessed, reconditioned, or recycled; and (h) damaged by accident, abuse, misuse, liquid contact, fire, earthquake or other external cause.

No warranty applies to any Product provided to Purchaser for which Masimo, or its authorized distributor, is not paid; and these Products are provided AS-IS without warranty.

Limitation of Warranty

Except as otherwise required by law or altered by the purchase agreement, the above warranty is the exclusive warranty that applies to the Product and software media, and Masimo does not make any other promises, conditions, or warranties regarding the Product. No other warranty applies, express or implied, including without limitation, any implied warranty of merchantability, fitness for a particular purpose, satisfactory quality, or as to the use of reasonable skill and care. See the licensing terms for the terms and conditions that apply to and Software accompanying the Product. Additionally, Masimo will not be liable for any incidental, indirect, special, or consequential loss, damage, or expense arising from the use or loss of use of any Products or Software. In no event shall Masimo's liability arising from any Product or Software (under contract, warranty, tort, strict liability, or otherwise) exceed the amount paid by purchaser for the Product or Software. The above limitations do not preclude any liability that cannot legally be disclaimed by contract.

Sales & End-User License Agreement

This document is a legal agreement between you ("purchaser") and Masimo Corporation ("Masimo") for the purchase of this Product ("Product") and a license in the included or embedded Software ("Software") except as otherwise expressly agreed in a separate contract for the acquisition of this Product, the following terms are the entire agreement between the parties regarding your purchase of this Product. If you do not agree to the terms of this agreement, promptly return the entire Product, including all accessories, in their original packages, with your sales receipt to Masimo for a full refund.

Restrictions

1. **Copyright Restrictions:** The Software and the accompanying written materials are copyrighted. Unauthorized copying of the Software, including Software that has been modified, merged, or included with other software, or the written materials is expressly forbidden. Purchaser may be held legally responsible for any copyright infringement that is caused or incurred by Purchaser's failure to abide by the terms of this Agreement. Nothing in this License provides any rights beyond those provided by 17 U.S.C. §117.
2. **Use Restrictions:** Purchaser may physically transfer the Product from one location to another provided that the Software is not copied. Purchaser may not electronically transfer the Software from the Product to any other device. Purchaser may not disclose, publish, translate, release, distribute copies of, modify, adapt, translate, reverse engineer, decompile, disassemble, or create derivative works based on the Software or the written materials.
3. **Transfer Restrictions:** In no event may Purchaser transfer, assign, rent, lease, sell, or otherwise dispose of the Product or the Software on a temporary basis. Purchaser shall not assign or transfer this License, in whole or in part, by operation of law or otherwise without Masimo's prior written consent; except that the Software and all of Purchaser's rights hereunder shall transfer automatically to any party that legally acquires title to the Product with which this Software is included. Any attempt to assign any rights, duties or obligations arising hereunder other than as set forth in this paragraph shall be void.
4. **U.S. Government Rights:** If Purchaser is acquiring Software (including the related documentation) on behalf of any part of the United State Government, the following provisions apply: the Software and documentation are deemed to be "commercial software" and "commercial computer software documentation," respectively pursuant to DFAR Section 227.7202 FAR 12.212, as applicable. Any use, modification, reproduction, release, performance, display or disclosure of the Software (including the related documentation) by the U.S. Government or any of its agencies shall be governed solely by the terms of this Agreement and shall be prohibited except to the extent expressly permitted by the terms of this Agreement.

Appendix: Concepts of Alarm Response Delay

Concepts of Alarm Response Delay

As with any pulse oximeter equipment, the audible and visual alarms are subject to alarm response delay, which is composed of Alarm Condition Delay and Alarm Signal Generation Delay. Alarm Condition Delay is the time from the occurrence of the triggering event to when the alarm system determines the alarm condition exists. While Alarm Signal Generation Delay is the time from the onset of an alarm condition to the generation of its alarm signal. The graphic below is a simplified illustration of the concept of alarm response delay and does not reflect actual lengths of delays.

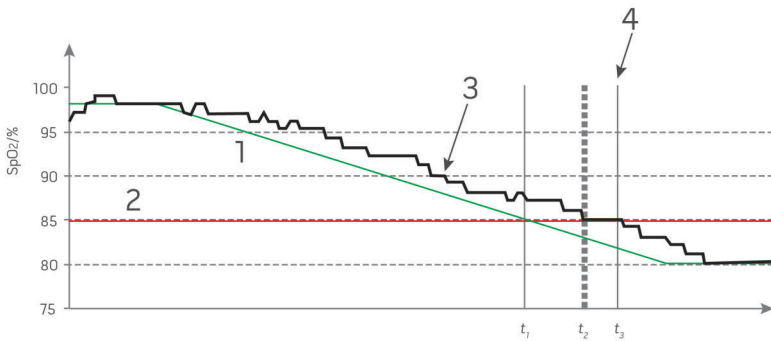

Reference	Definition
1	SaO ₂
2	Alarm Limit
3	Displayed SpO ₂
4	Alarm Signal Generation
SpO ₂	Saturation
t	Time

The Alarm Condition Delay is graphically represented as $t_2 - t_1$ in the figure above to show the delay due to processing and averaging.

The Alarm Signal Generation Delay is graphically represented as $t_3 - t_2$ in the figure above to show the delay due to alarm system strategy and communication time.

The overall alarm system delay time is graphically represented as $t_3 - t_1$.

For more information about alarm response delay, refer to ISO 80601-2-61.

Index

3

3D Alarms • 58, 59, 128

A

About • 57, 97

About Alarms • 48, 89, 124, 128

About Desat Index • 62, 128

About Parameter Information • 62, 64, 65, 66, 67, 68, 71, 74, 76, 77, 78, 81, 82, 83, 89, 97

About Pi Delta • 128, 129

About the Action Menu • 48, 51, 52, 114, 115

About the Main Screen • 43, 48

About the Status Bar • 26, 48, 49, 85, 87, 91, 92, 93, 96, 126

About the System Status Light • 38, 56

About This Manual • 7

AC Power Indicator • 50

Access Control • 40, 85, 86, 94, 103, 107

Accessing Main Menu Options • 48, 57, 106

Accuracy • 151

Accuracy (ARMS*) • 146

Acoustic Waveform View • 79

Acquisition System • 33

Adaptive Threshold Alarm (ATA) Feature • 63, 127

Additional Settings • 57, 59, 78

Additional Settings for NIBP • 80, 84

Additional Settings for Pi • 65, 66

Additional Settings for PVi • 66, 67

Additional Settings for RRa • 67, 68, 69

Additional Settings for RRp • 67, 70, 71

Additional Settings for SpHb • 71, 73

Additional Settings for SpO2 • 62, 63, 90

Admitting a Patient • 118

Alarm Interface • 123

Alarm Limit Test • 169

Alarms • 153

Appendix

Concepts of Alarm Response Delay • 177

Attach NIBP Cuff • 42

Audio Pause • 49, 85, 96, 126

Automatic Interval Measurement • 52, 113

B

Back View • 37, 41, 100, 169

Battery Charge Status Indicator • 50, 51, 172

Battery Operation and Maintenance • 41, 172

Blood Pressure Measurement • 112

Bluetooth • 49, 86, 92, 121

Brightness • 86, 94, 141, 172

C

Calibration • 170

Calibration for NIBP • 80, 85

Capturing Screenshots • 100

Changing Profiles • 103

Chapter 1

Technology Overview • 23

Chapter 10

Troubleshooting • 123, 137, 168

Chapter 11

Specifications • 145

Chapter 12

Service and Maintenance • 85, 134, 135, 136, 167

Chapter 2

Description • 35

Chapter 3

Setting Up • 39

Chapter 4

Operation • 43

Chapter 5

- Profiles • 49, 57, 95, 103, 109, 172

Chapter 6

- Noninvasive Blood Pressure (NIBP) • 42, 109

Chapter 7

- Admit to and Discharge from Patient SafetyNet • 101, 117

Chapter 8

- Third-Party Devices • 42, 121

Chapter 9

- Alarms and Messages • 123, 139, 140

- Citations • 33, 164

- Citations for Pleth Variability Index (PVi) • 25

- Cleaning • 167, 173

- Cleaning and Service Warnings and Cautions • 20

- Compliance • 154

- Compliance Warnings and Cautions • 21

- Concepts of Alarm Response Delay • 177

- Connect Device to Rad-97 • 121

- Connectors • 155

- Contacting Masimo • 140, 141, 142, 143, 173

- Continuous Monitoring • 88

- Contraindications • 11

- Cuff Selection and Placement • 110, 112, 113, 115

- Customizing Trend View • 51, 53, 54, 97

- Customizing Windows • 53, 55

D

- Desat Index • 128, 129

- Device Mode • 86, 88

- Device Output • 41, 49, 87, 96, 142, 169

- Device Settings • 57, 86, 134

- Discharging a Patient • 120

- Display Indicators • 153

- Display Range • 145

- www.masimo.com

- Downloading Screenshots • 100

E

- Electrical • 151

- Environmental • 39, 152

- Ethernet • 49, 86, 91

- Exclusions • 174

F

- FastSat Overview • 63

- Features • 36

- Front View • 36

- Functional Oxygen Saturation (SpO₂) • 24

G

- General Description for Carboxyhemoglobin (SpCO) • 29

- General Description for Methemoglobin (SpMet) • 30

- General Description for Oxygen Reserve Index (ORi) • 31

- General Description for Oxygen Saturation (SpO₂) • 24

- General Description for Perfusion Index (Pi) • 25

- General Description for Pleth Variability Index (PVi) • 25

- General Description for Pulse Rate (PR) • 25

- General Description for Respiration Rate (RRp) • 30

- General Description for SpOC • 29

- General Description for Total Arterial Oxygen Content (CaO₂) • 29

- General Description for Total Hemoglobin (SpHb) • 28

- General System Description • 35

Guidance and Manufacturer's Declaration-Electromagnetic Emissions • 158

Guidance and Manufacturer's Declaration-Electromagnetic Immunity • 158

Guidelines for Setting Up • 39

H

Home • 58, 86, 89, 99, 103

I

In Vivo Adjustment Overview • 61, 64, 73, 75, 76, 77

In Vivo for SpCO • 61, 76

In Vivo for SpHb • 61, 71, 73

In Vivo for SpMet • 61, 74, 75

In Vivo for SpO₂ • 61, 62, 64

Indications for Use • 10

Initial Battery Charging • 39, 41, 172

Intervals for NIBP • 80, 84

K

Kite • 15, 20

L

Limitation of Warranty • 174

Limited Warranty • 173

Localization • 50, 86, 87, 138

M

Maintenance • 172

MAP Alarms • 82, 83

MAP Settings • 81, 82

Masimo Kite • 42

Masimo rainbow SET® Parallel Engines • 23

Masimo SET® DST • 24

Measurement Range • 150

Messages • 130

Monitoring Resumed Message • 119

N

Navigating the Main Menu • 58

NIBP Air Leak Test • 170

NIBP Module Calibration • 170

Noninvasive Blood Pressure • 14, 19, 170

Noninvasive Blood Pressure (NIBP) Messages • 135

Noninvasive Blood Pressure (NIBP) Settings • 57, 80

Noninvasive Blood Pressure (NIBP) Specifications • 150

Not Admitted • 117

Not Monitoring Message • 119

Nurse Call Connection • 37, 41

Nurse Call Setting Connections • 41, 167

Nurse Call Test • 169

O

Operation - NIBP • 109

ORi Alarms • 77

ORi Settings • 60, 77

Overpressure Test • 171

P

Parameter Settings • 57, 59, 60

Parameter Settings for Noninvasive Blood Pressure (NIBP) • 80, 81

Patient • 32

Patient Admit/Discharge • 48, 101

Patient Category • 109

Patient Conditions • 109

Patient SafetyNet • 20

Performance Verification • 168

Performance Warnings and Cautions • 15

Physical Characteristics • 152
 Pi Alarms • 65
 Pi Delta • 65, 128, 129, 130
 Pi Settings • 60, 65
 Pleth + Sig IQ + Acoustic View • 80
 Powering the Rad-97 ON and OFF • 40, 43
 Power-On Self-Test • 168
 PR Alarms • 64
 PR Settings • 60, 64
 Preparation for Use • 39
 Pressure Range • 151
 Product Description • 9
 Product Description, Features and Indications for Use • 9
 Profiles Overview • 43, 103, 107
 Profiles Settings • 106
 Pulse CO-Oximetry Specifications • 145
 Pulse CO-Oximetry vs. Drawn Whole Blood Measurements • 28
 Pulse Rate (PR) • 81, 83
 Pulse Rate Alarms • 83
 PVi Alarms • 66
 PVi Settings • 60, 66

R

Rad-97 Battery • 41, 50, 51, 86, 93
 Rad-97 Screenshot Capture • 99
 rainbow Acoustic Monitoring Architecture • 32
 rainbow Acoustic Monitoring™ (RAM™) • 31, 68
 rainbow Parameter Settings • 57, 59, 124
 rainbow Pulse CO-Oximetry Technology • 26
 Recommended Separation Distances • 161
 Regulatory Notice • 9
 Repair Policy • 173

Replacing Factory Default Settings for Adult, Pediatric and Neonatal Profiles • 95, 107
 Resolution • 149
 Respiration Rate (RR) Settings • 60, 67
 Restrictions • 175
 Return Procedure • 39, 173
 RRa Alarms • 67, 68
 RRa Settings • 67, 68
 RRp Alarms • 67, 70
 RRp Settings • 67, 69
 Run Time for Rad-97 • 172

S

Safety Information, Warnings and Cautions • 13, 29, 30, 31, 39, 137
 Safety Warnings and Cautions • 13
 Sales & End-User License Agreement • 175
 Screen Orientation • 86, 91
 Sensitivity Modes Overview • 51, 52, 78, 137, 139
 Sensor • 32
 Side and Top Views • 38, 39, 56
 Signal Extraction Technology® (SET®) • 23
 Signal IQ • 26
 Signal IQ Indicators • 79, 133
 Signal Processing • 33
 Silencing Alarms • 49, 125
 Sleep Study • 63, 90, 103
 Sounds • 50, 57, 78, 85, 95, 127
 Span Point Calibration • 171
 SpCO Alarms • 76
 SpCO Settings • 60, 76
 SpCO, SpMet, and SpHb Measurements During Patient Motion • 31
 SpHb Alarms • 71, 72
 SpHb Settings • 60, 71

SpMet Alarms • 74, 75
 SpMet Settings • 60, 74
 SpO2 Alarms • 62, 128, 169
 SpO2 Performance Specifications • 148
 SpO2 Settings • 60, 62, 79
 SpOC Alarms • 74
 SpOC Settings • 60, 74
 Spot Check NIBP Measurement • 112
 Stat Interval NIBP Measurement • 51, 114
 Successful Monitoring for ORi • 31
 Successful Monitoring for SpCO • 30, 134
 Successful Monitoring for SpHb • 29, 134
 Successful Monitoring for SpMet • 30, 134
 Successful Monitoring for SpO2, PR and Pi • 24
 Symbols • 162
 SYS/DIA Alarms • 81
 SYS/DIA Settings • 81

T

Testing with the optional Masimo SET Tester • 169
 Third-Party Devices • 42
 Touchscreen Function Test • 169
 Trend Settings • 97
 Trends • 58, 62, 64, 65, 66, 67, 71, 74, 76, 77, 97
 Trends for NIBP • 52, 81, 82
 Troubleshooting Measurements • 29, 31, 133, 137
 Troubleshooting Rad-97 • 140

U

Understanding Windows • 44, 48, 53
 Unpacking and Inspection • 39
 Using the Touchscreen and Home Button • 43

Using the Touchscreen Interface • 44

W

Waveform Mode • 48, 78, 79
 Wi-Fi • 49, 86, 92, 143
 Wireless Specifications • 155

Z

Zero Point Calibration • 171



www.masimo.com

38281/LAB-9275B-0917